

# Cross-Modal Illusory Conjunctions Between Vision and Touch

Caterina Cinel  
The University of Birmingham and University of Essex

Glyn W. Humphreys  
The University of Birmingham

Riccardo Poli  
University of Essex

Cross-modal illusory conjunctions (ICs) happen when, under conditions of divided attention, felt textures are reported as being seen or vice versa. Experiments provided evidence for these errors, demonstrated that ICs are more frequent if tactile and visual stimuli are in the same hemispace, and showed that ICs still occur under forced-choice conditions but do not occur when attention to the felt texture is increased. Cross-modal ICs were also found in a patient with parietal damage even with relatively long presentations of visual stimuli. The data are consistent with there being cross-modal integration of sensory information, with the modality of origin sometimes being misattributed when attention is constrained. The empirical conclusions from the experiments are supported by formal models.

There is increasing experimental evidence that perceptual processing within one modality can be influenced by stimuli presented within another modality. For instance, studies of attentional cuing show that cues presented in one modality (e.g., touch) can influence the speed of responding to stimuli presented in a different modality (e.g., vision; Buchtel & Butter, 1988; Butter, Buchtel, & Santucci, 1989; Spence & Driver, 1997; Spence, Nicholls, Gillespie, & Driver, 1998; Spence, Pavani, & Driver, 2000). These effects are found not only in normal observers but also (and perhaps more dramatically) with neuropsychological patients. After unilateral brain insult, patients can manifest *extinction*, in which they fail to detect a stimulus presented on the contralesional side when another stimulus is presented simultaneously on the ipsilesional side. Mattingley, Driver, Beschin, and Robertson (1997) reported that extinction could occur even when the contralesional stimulus was visual and the ipsilesional stimulus was tactile (and vice versa). In this case, detection in one modality is affected by concurrent stimulation in another. There is also evidence that information can be linked across modalities to create new perceptual experiences. In the phenomenon of synesthesia,

stimulation in one sensory modality can cause sensation in other, different modalities in such a way that, for example, a synesthete might perceive color, shape, or flavor of someone's voice (Cytowic, 1989). In less extreme circumstances, visual information conveyed by the lips can alter heard sounds, as in the McGurk effect (McGurk & MacDonald, 1976). Phenomena such as this suggest that not only can responses in one modality be affected by responses in another modality but also that one's conscious experience can sometimes be based on transformations of one input into another modality. Further evidence of multimodal interaction is also provided by neurophysiological studies in which, at different levels of the central nervous system, the presence of multimodal neurons has been detected (e.g., Stein & Wallace, 1996, 1999).

In the present study, we demonstrate that transformations between vision and touch can be observed in normal observers under laboratory conditions. In the past, studies involving vision and touch have tried to show, when information about one object is discrepant between two senses, whether people rely more on vision or touch (i.e., whether one sense dominates over the other). Over many years of research, it has been found that perceptual dominance between vision and touch can depend on the nature of the task that observers have to perform. For instance, when required to judge object size, people seem to rely much more on vision than touch (e.g., Rock & Victor, 1964). However, in tasks requiring texture judgments (e.g., smoothness, roughness), people can rely equally on one or the other sense (Heller, 1982; Jones & O'Neil, 1985; Lederman & Abbott, 1981), or touch can dominate over vision (Lederman, Thorne, & Jones, 1986). In a similar manner, Klatzky, Lederman, and Matula (1993) found that people, when allowed to use vision and touch for judging object properties, used touch more frequently if required to make difficult judgments about stimulus material and less frequently to judge geometric properties.

In the present study, in which simultaneous perception of visual and tactile textures was involved, we studied whether illusory

---

Caterina Cinel, Behavioural and Brain Sciences Centre, School of Psychology, The University of Birmingham, Edgbaston, United Kingdom, and Department of Psychology, University of Essex, Wivenhoe Park, Colchester, United Kingdom; Glyn W. Humphreys, Behavioural and Brain Sciences Centre, School of Psychology, The University of Birmingham, Edgbaston, United Kingdom; Riccardo Poli, Department of Computer Science, University of Essex, Wivenhoe Park, Colchester, United Kingdom.

This work was supported by a grant from the Medical Research Council to Glyn W. Humphreys. We thank participant M.H. for very kindly taking part. We also thank Bill Prinzmetal for his suggestions about our formal model and two anonymous reviewers for their helpful comments.

Correspondence concerning this article should be addressed to Caterina Cinel, Department of Psychology, University of Essex, Wivenhoe Park, Colchester CO4 3SQ, United Kingdom. E-mail: ccinel@essex.ac.uk

conjunctions (ICs) could occur across modalities. Treisman and Schmidt (1982) conducted the first experimental study of ICs within vision. They presented colored shapes flanked by numbers. Participants had to report the numbers and then the shapes and their colors. The authors found that reports sometimes reflected miscombinations (or ICs) of shape and color. Furthermore, these ICs occurred more frequently than would be expected from the level of *feature errors*, found when participants reported a shape or a color not actually present in the display (however, see Donk, 1999, for an alternative view). Treisman and Schmidt suggested that different visual features may be coded independently by early preattentive vision, with the features being represented in separate spatial maps. Subsequently, the features are bound by attention to their common location (Treisman, 1998; Treisman & Gelade, 1980). Treisman has suggested that, to locate and bind the features, an “attention window moves within the location map and selects from the feature maps whatever features are currently linked to the attended location” (Treisman, 1998, p. 1296). This provides the central assumption behind feature integration theory (FIT). However, several studies have shown that at the preattentive stage of visual processing, spatial information can be available to constrain integration. Cohen and Ivry (1989), in a study on ICs, have shown that the more distant two stimuli are, the less frequent ICs are. Other studies have also shown effects of grouping on ICs. Prinzmetal (1981) found that ICs are more frequent between stimuli that are grouped together than between stimuli that are not grouped, suggesting that object segmentation can take place even at preattentive stages of processing (see also Humphreys, Cinel, Wolfe, Olson, & Klempen, 2000).

One more open question concerns the nature of ICs and the level at which ICs originate. According to FIT, ICs are perceptual in nature, reflecting incorrect binding of features. However, it is possible that ICs are due to memory failures. Participants may encode features and bind them correctly, but this binding may be rapidly lost in memory. Treisman and Schmidt (1982) have tried to test this possible alternative. In their Experiment I, they asked participants to report their level of confidence after each response, and at least on some occasions, ICs were reported with high confidence as being perceptually experienced. On these occasions, ICs do not seem to stem from guesses made following the encoding of shapes and colors. In their Experiments II and III, Treisman and Schmidt gave the participants a matching task in which a probe was presented either in advance (Experiment II) or in the stimulus display (Experiment III). The authors reasoned that ICs due to memory failures should decrease under these circumstances. However, in both experiments, ICs were still observed to an equal degree as before. Such results suggest that ICs can be perceptual in origin, even if memory failures can also contribute. It is interesting that there are also indications that ICs can occur at various levels of stimulus representation. Virzi and Egeth (1984), for instance, presented participants with color names and adjectives in colored ink (e.g., the word *BROWN* in red ink and the word *HEAVY* in green ink). They found that participants sometimes made semantic illusions by reporting the word *RED* in green ink or the word *HEAVY* in brown ink. Whether such errors are of the same kind as those described by Treisman and Schmidt at lower perceptual levels is still questionable.

To date, ICs have been demonstrated only between features presented within the same modality (typically in the visual modal-

ity, but also in audition; e.g., Hall, Pastore, Acker, & Huang, 2000). Here, we assessed whether ICs could also be formed from stimuli presented in different modalities. Such a result could be consistent with the idea that, at a preattentive level, there is pooling of information from different modalities.

In Experiment 1, we report that there can be cross-modal ICs in which textures that are felt are reported as having been seen. In Experiment 2, we show that these cross-modal ICs can be more frequent when tactile and visual stimuli are presented in the same hemispace than when they are presented in different hemispaces, consistent with a perceptual locus to the effect. In Experiment 3, we provide more evidence for a perceptual rather than a memorial account of ICs, using a forced-choice response procedure. In Experiment 4, we show that tactile ICs can be eliminated by requiring participants to attend to and report the tactile texture (even though the memory load then increased). Cross-modal ICs are reduced by attention to the sensory stimulus. In Experiment 5, we present further confirmatory evidence for a perceptual locus for the effect. We report data from a patient with parietal damage who showed significant numbers of cross-modal ICs, even with long stimulus exposure, but only in a condition stressing simultaneous perception of visual and tactile stimuli. Finally, in Experiment 6, we report the occurrence of the opposite class of cross-modal ICs (visual stimuli reported as tactile). This demonstrates that there is nothing intrinsic to one sensory modality that leads to cross-modal ICs (e.g., tactile sensory information being less tied to its modality). Cross-modal visual→tactile ICs were as frequent as cross-modal tactile→visual ICs, under similar presentation conditions. Taken together, the evidence is consistent with the idea that information converges preattentively for binding from different sensory modalities and that this binding process is modulated by the parietal lobe.

## Experiment 1

The purpose of Experiment 1 was to test for the presence of ICs between visual and tactile stimuli. The tactile stimuli were rigid bars whose surfaces had different kinds of texture. The visual stimuli were drawn from a set of three shapes and four textures (the same as the tactile stimuli, digitized through a video camera). Visual and tactile stimuli were briefly presented simultaneously. Participants had two tasks. First, they had to identify the orientation of the tactile stimulus, and then they had to identify the textures and the shapes of the two visual stimuli. *Tactile→visual conjunction errors* were made when the texture of the tactile stimulus was assigned to one of the two visual stimuli. These were compared with *texture feature errors*, those made on trials in which participants reported the presence of a texture not present in either vision or touch.

## Method

*Participants.* A total of 16 students of The University of Birmingham were tested. Their ages fell between 18 and 28 years. All participants had normal or corrected-to-normal vision and normal color vision.

*Stimuli.* The tactile stimuli consisted of four rectangular bars (about 12 × 3 cm), each one having a different surface. The textures were chosen so that very different feelings were perceived by touching the bars, and each texture could be easily recognized both by touch and vision. Four kinds of textures were used, obtained by gluing carpet, a Lego brick,

synthetic fur, and dried beans onto cardboard bars (the textures had different colors). The visual stimuli had three possible shapes—either a square ( $5.5 \times 5.5$  cm), a triangle ( $8 \times 4$  cm), or a circle (5.5-cm diameter)—and four possible surfaces, the same as the tactile stimuli.

**Procedure.** Each participant was seated at a table where one tactile stimulus was placed by the experimenter on each trial. A cardboard screen was placed on the table so that each participant could touch each tactile stimulus without seeing it (see Figure 1). Participants used their preferred hand to touch the bar. On each trial, one tactile stimulus and two visual stimuli were presented. The tactile stimulus was positioned in either a horizontal or a vertical orientation (each bar was attached to  $25 \times 20$  cm rectangular cardboard, which helped the experimenter to keep each tactile stimulus steady while the participants were touching it). The two visual stimuli were aligned vertically for half of the participants and horizontally for the other half, and they were equidistant from the center of the display (in both cases, the distance between the centers of the stimuli was about 7 cm).

Participants faced the computer screen where, first, a fixation cross appeared for 1 s, and this was followed by the display of two textured shapes. The exposure duration for the shapes was set for individual participants so that they achieved an accuracy score of between 75% and 90% correct report of the visual stimuli (both shapes and textures). Errors occurred when at least one feature of the visual stimuli was reported erroneously. The average stimulus duration over participants was 184 ms, with a range of 75–300 ms ( $SD = 75.1$ ). After the visual stimuli disappeared, a mask was presented for 90 ms. Each participant was told that the tactile stimulus—which was kept in position by the experimenter—should be touched as soon as the fixation cross appeared. He or she was also asked to touch the stimulus for the time strictly necessary to recognize its orientation. In that way, the participant sensed the visual stimuli while he or she was touching the tactile stimulus. (However, the tactile stimulus was perceived for a longer period of time than the visual stimuli.) Between trials, participants kept their hands on the table. The first task of the participants was to name the orientation (either vertical or horizontal) of the tactile stimulus. This was done to make the participants sense the tactile stimulus without necessarily focusing their attention on its texture. Also, we thought that orientation discrimination was an easy task to be performed quickly by the participants (although not formally recorded, this took less than 2 s). The second task was to report the shape and texture of the visual items.

All possible combinations of shapes and textures were presented within a block of trials. The shapes and textures of each visual stimulus pair were always different, and the tactile stimulus could have either a different or the same texture as one of the two visual stimuli. Two blocks of 72 trials each were run for each participant, in one session. Participants were first given verbal instructions in which all the stimuli were shown and the textures named. The words used by the experimenter to name the textures were *beans*, *carpet*, *fur*, and *Lego*. However, participants were allowed to use

synonyms (e.g., several participants preferred to use the word *brick* instead of *Lego*). The experimenter ensured that visual and tactile stimuli could be correctly recognized by the participants. Then a practice session followed to set the exposure duration of the visual display. The number of trials in each practice session varied from participant to participant. A block of at least 10 trials was first given to make the participant confident with the task (for these trials, the visual stimuli were presented for 500 ms). Then, further blocks of 10 trials were presented until the accuracy achieved was in the range required. After the first block of experimental trials, the accuracy level was calculated; if it was not in the range required, the duration was changed for the second block of trials. On each trial, the answer given by the participants was written on paper by the experimenter.

## Results and Discussion

The percentages of correct responses and errors made by the participants are reported in Table 1. The results were divided into two different conditions. The *different texture condition* includes those trials in which neither visual stimulus had the same texture as the tactile stimulus. The *same texture condition* includes those trials in which the texture of the tactile stimulus was the same as one of the two visual stimuli. Two kinds of errors could be made to the visual stimuli: feature and conjunction errors. Feature errors were made when the participants incorrectly reported features of the visual stimuli that were not present in that trial. These errors could be further classified into *shape feature* and *texture feature errors*, according to whether they were made to the shape or texture properties of the stimuli. Conjunction errors were made when the participants incorrectly described the features of a visual target using features belonging to another stimulus on that trial. Two kinds of conjunction errors could be made: *visual conjunction errors* were classified when the texture or the shape of one visual stimulus was assigned to the other visual stimulus. A more precise classification of these errors was not possible (i.e., according to whether they were based on properties derived from the left or right stimulus) because participants were not asked to report the items in any particular order. We note, however, that responses were typically ordered from left to right so that participants would report (for example) a square with a carpet texture followed by a circle with a fur texture. *Tactile*→*visual conjunction errors* were made when the texture of the tactile stimulus was reported instead of the texture of one of the two visual stimuli. In the same texture condition, tactile→visual conjunction errors could not be scored because they could not be distinguished from visual conjunction errors. Hence, to assess tactile ICs, the different texture condition was critical. For this condition, tactile→visual conjunction errors were compared with texture feature errors. If tactile→visual conjunction errors were due to chance report of one of the possible textures from the set, we would expect their frequency to be approximately the same as the frequency of texture feature errors. If, however, participants made true ICs, then we would expect conjunction errors to be more frequent than feature errors. The frequency of tactile→visual conjunction errors (8.70%) was higher than the frequency of texture feature errors (4.58%; ratio = 1.9:1), and this difference was significant,  $t(15) = 4.03, p < .01$ . The ratio of tactile ICs to texture feature errors across participants varied from 0.75:1 to 10:1 ( $SD = 2.57$ ). These results demonstrate that ICs are possible not only within the visual modality but also between two different modalities: vision and touch. Visual conjunction errors could also be assessed if the shape of one visual

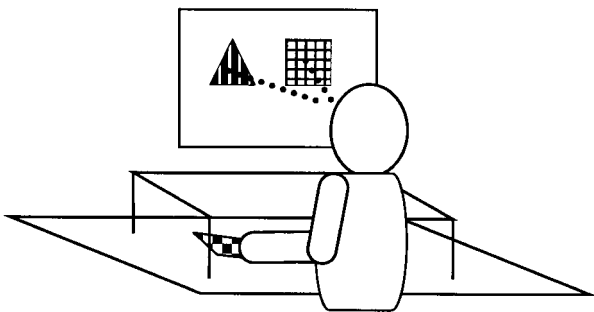

Figure 1. Experimental setup in Experiment 1; different shape patterns represent different textures.

Table 1  
*Percentages of Responses Given by the Participants in  
 Experiment 1, According to Whether the Tactile Texture Was  
 the Same as or Different From One Visual Texture*

Responses	Texture	
	Different	Same
Correct	76.29	80.10
One item incorrect		
Tactile→visual conj.	8.70	
Texture feature	4.58	9.11
Shape feature	7.27	7.48
Texture and shape feature	0.35	0.72
Tactile→visual conj. and shape feature	0.45	0.19
Two items incorrect		
Visual conj.	0.44	0.45
One texture feature, one shape feature	0.34	0.52
One tactile conj., one texture feature	0.25	0.00
One tactile conj., one shape feature	0.45	0.00
Other errors	0.88	1.43

*Note.* conj. = conjunction.

stimulus was reported with the texture of the other: for example, a square with a synthetic fur texture and a triangle with a carpet texture being reported as a square with a carpet texture and a triangle with a fur texture. There were no visual conjunction errors on trials in which one stimulus was fully reported correctly, and on trials in which both stimuli were reported incorrectly, visual conjunction errors were no greater than trials on which either a texture or a shape feature error occurred (visual conjunction errors: different texture condition = 0.44, same texture condition = 0.45; feature errors [either texture or shape errors] in both visual stimuli: different texture condition = 0.34, same texture condition = 0.68). The lack of visual ICs may be because participants were required to report the visual stimuli under conditions of maximal attention within that modality. This may reduce the likelihood that their features might enter into incorrect combinations. The effects of attention on ICs were examined further in Experiment 4 here.

One other result to note is that texture feature errors were more likely on trials in which the tactile texture was the same as one of the visual textures (same texture trials) than on trials when the tactile and visual textures differed (different texture trials; 9.11% vs. 4.58%). However, it is difficult to make definite conclusions from this result because, on the same texture trials, there was the possibility of making two types of texture feature errors (because there were two textures that were not shown on those trials), whereas only one type of texture feature error could be made on a different texture trial (then only one texture that was not presented). There also tended to be improved report for the visual stimulus sharing the texture with the tactile stimulus, relative to the visual stimulus that did not (5.87% of texture feature errors on the visual stimulus with different texture, and 3.07% on the stimulus with same texture),  $t(15) = 3.24, p < .01$ . On trials in which one texture was shared across modalities, that texture tended to be reported at the expense of the other visual texture present. After reporting all the present experiments, we present a formal account of the errors in this experiment, to assess whether performance could be best explained using a model in which cross-modal binding is assumed to operate.

## Experiment 2: An Effect of Common Hemisphere

Experiment 1 showed effects of the tactile texture on responses to the visual stimuli, particularly in terms of increased numbers of conjunction errors relative to visual texture errors. There was no evidence for visual ICs. This suggests that unattended attributes (such as tactile textures) may enter into incorrect stimulus combinations, including feature combinations formed across different modalities. The tactile textures may be susceptible to entering into such errors because they were unattended (given that the task was to respond to the orientation but not the texture of the tactile stimulus). The visual textures, however, were initially attended. It may be that, without attention, features are coded but not bound to their perceptual modalities. This allows features to bind, incorrectly, across modalities. This account is similar to the explanation of within-modality ICs offered by FIT (e.g., Treisman, 1998; see the introduction). An alternative account, however, is that the errors arise in memory. For example, the visual and tactile textures may initially be labeled appropriately for their modality of input, but this information may be rapidly forgotten. As a consequence, participants may be left with knowledge about the textures present (the tactile as well as the visual) but with no information about their input modality. There may similarly be rapid loss of information about texture–shape pairings. Responses may then reflect arbitrary pairings of the shapes and textures present.

In Experiment 2, we provided one test of whether the cross-modal ICs were perceptual in nature, by examining whether these ICs were influenced by the relative locations of the visual and tactile stimuli. In particular, Experiment 2 assessed whether cross-modal ICs were more likely between visual and tactile stimuli presented to the same side of space relative to the body (i.e., in the same hemisphere) compared with stimuli presented to different hemispheres. If co-occurrence in the same hemisphere is important, this would provide direct evidence for a perceptual attribute (location on one side of the body) influencing performance. This would fit with a perceptual account of cross-modal ICs.

The stimuli were the same as those used in Experiment 1. However, on each trial, two visual stimuli and two tactile stimuli were now presented simultaneously. The visual stimuli were always aligned horizontally, one on the left and the other on the right side of the display. The tactile stimuli had a similar alignment to the visual stimuli. The participants had to touch the tactile stimuli with both hands—the left stimulus with the left hand and the right stimulus with the right hand—and they had to judge whether the felt orientations were the same or different. Following this, they had to report the visual shapes and textures presented. Are cross-modal ICs greater when the felt and seen stimuli fall on the same side of the body (in the same rather than in opposite hemispheres)?

## Method

*Participants.* A total of 20 participants from The University of Birmingham took part in the experiment. Their ages fell between 18 and 23 years. All participants had normal or corrected-to-normal vision and normal color vision.

*Stimuli and procedure.* The stimuli were the same used in Experiment 1. The visual stimuli were always aligned horizontally, equidistant from the center of the screen. On each trial, the sequence of displays was the same as in Experiment 1, but now two tactile strips were presented. The tactile strips were placed on the table either in the same or in different orientations

(e.g., both vertical, or one vertical and the other horizontal, etc.). The participants were asked to touch the tactile stimuli with both hands: the left stimulus with the left hand and the right stimulus with the right hand. They had two tasks: first, to report whether the tactile items had the same or different orientations and second, to report the shape and texture of both visual items.

On every trial, the tactile items had different textures. To simplify the conditions, we kept constant the texture and side of presentation of one of the tactile stimuli for each participant, whereas its orientation could vary. The constant texture was presented on the left side for half the participants and on the right side for the other half. The texture that was constant was balanced across participants. The visual items always differed both in shape and texture. All possible combinations of texture and shape were presented to each participant, in a random order (with the constraint that one tactile texture was always constant). One visual item had the same texture as one of the two tactile stimuli. Visual and tactile stimuli with a common texture were in the same hemisphere on half the trials and, on the remaining trials, the stimuli with the common texture were in opposite hemispheres. The procedure was similar to that used in Experiment 1. A fixation cross appeared for 1 s, followed by the visual display. The presentation time for the visual display was again set for individual participants to ensure that performance fell between 75% and 90% correct. The average duration, across participants, was 129 ms, with a range of 60–400 ms. A mask followed the visual stimuli (for 90 ms).

*Experimental design.* The combinations of conditions are shown in Figure 2. When visual and tactile stimuli with a common texture were in the same hemisphere (Figures 2A and 2C), tactile→visual conjunction errors on the visual item with common texture were possible only with the tactile item in the opposite hemisphere (see Figures 2A and 2C, Error Types 1, 6, 9, and 14). In contrast, tactile→visual conjunction errors on the item with a different texture were possible only with the tactile item in the same hemisphere (Error Types 2, 5, 10, and 13). When visual and tactile items with the common texture were in opposite hemispheres (Figures 2B and 2D), tactile→visual conjunction errors on the visual item with the common texture were possible only when the tactile item fell in the same hemisphere (Error Types 3, 8, 11, and 16). Tactile→visual conjunction errors on the visual item with the different texture could occur only when the visual and tactile textures fell in opposite hemispheres (Figure 2B, Error Types 4, 7, 12, and 15).

## Results and Discussion

The most critical aspect of this experiment is whether cross-modal ICs were more likely between stimuli that fell on the same side of space, relative to stimuli that fell in opposite hemispheres. We term this the *effect of coregistration*. Note that, as in Experiment 1, cross-modal ICs could only be scored unambiguously when the tactile texture was different from the visual textures (an error to a common texture could be visual or tactile in origin).

To investigate the effects of coregistration, we broke down performance as follows. First, the data were categorized according to whether an IC (when present) arose from a tactile texture coregistered with the visual item to which the error was made (coregistered = Errors 2, 3, 5, 8, 10, 11, 13, and 16, Figure 2; not coregistered = Errors 1, 4, 6, 7, 9, 12, 14, and 15). Second, performance was separated according to whether the constant tactile texture was on the left or right (Figures 2A and 2B vs. Figures 2C and 2D). These data were subjected to a mixed-design analysis of variance (ANOVA; see Figure 3). There was one between-subjects factor: location of the constant tactile texture (called *constant stimulus hemisphere*, either left or right). There were two within-subjects factors: (a) relevant visual texture in the same or opposite location as the relevant tactile texture (called

*hemisphere*), and (b) the error type (tactile→visual conjunction vs. texture feature errors). Feature errors were defined if errors to the visual textures involved textures not present in either the visual display or the tactile stimulus. Tactile→visual conjunction errors and feature errors were assigned to the categories defining the cells in the ANOVA according to the visual texture to which the error was made. The raw data are shown in Table 2. (The way that texture feature errors were assigned either to the same- or the opposite-hemisphere condition is described in the *Method* section of this experiment and shown in Figure 2). The difference between conjunction and feature errors was significant,  $F(1, 18) = 11.82, p < .01$ , showing that true ICs were made by the participants. The interaction between hemisphere and error type was not significant,  $F(1, 18) = 1.85, p = .19$ . However, the interaction between hemisphere, error type, and constant stimulus hemisphere was significant,  $F(1, 18) = 4.75, p = .04$ . ICs were more frequent when visual and tactile stimuli were in the same hemisphere than when they were in opposite hemispheres, but only when the constant tactile stimulus was on the right side. Two separate two-way ANOVAs, one for participants with the constant stimulus on the left and one for the participants with the constant stimulus on the right, showed that the interaction between hemisphere and error type was not significant for the left group,  $F(1, 19) = 0.38, p = .55$ , whereas it was significant for the group with the constant item on the right,  $F(1, 19) = 5.76, p = .04$ .

The increase of tactile→visual conjunction errors over texture feature errors was most pronounced when the constant tactile item was on the right, and it was also then greater for textures in the same hemisphere (in Figure 2, Error Types 10, 11, 13, and 16) than for textures in different locations (Error Types 9, 12, 14, and 15). With the constant item on the left, the frequency of ICs was lower and the increase in ICs over texture feature errors for stimuli in the same hemisphere was not reliable (in Figure 2, Error Types 2, 3, 5, and 8 vs. Error Types 1, 4, 6, and 7).

Tactile→visual conjunction errors again occurred at a rate significantly higher than the rate of texture feature errors. Moreover, this effect was particularly strong when the visual and tactile stimuli fell in the same hemisphere than when they were presented in opposite hemispheres. This provides converging evidence for tactile ICs having a perceptual locus, because coregistration of hemisphere influenced the frequency of ICs errors. The results also go against a memory account of the effects. In a memory account, IC errors would be expected particularly for the stimuli reported second (because there would then be a greater likelihood that information about the co-occurrence of the visual shapes and their texture, and about the modality of the texture, would be forgotten). This would hold even if stimulus location served as a cue for memory retrieval. In general, participants reported the visual shapes and textures from left to right. On a memory view, cross-modal ICs should be frequent for Error Types 10, 12, 14, and 16 in Figure 2 (taking any cases in which the constant tactile item was on the right). Instead of this, ICs were increased for Error Types 10, 11, 13, and 16 compared with Error Types 9, 12, 14, and 15, even though the raised rates occurred for the visual stimulus reported first on half the occasions (Error Types 11 and 13). We also found that ICs were raised when the constant tactile texture was on the right relative to when it was on the left. It is unclear why this factor modulated performance. However, one possibility is that tactile ICs are particularly likely to arise when participants

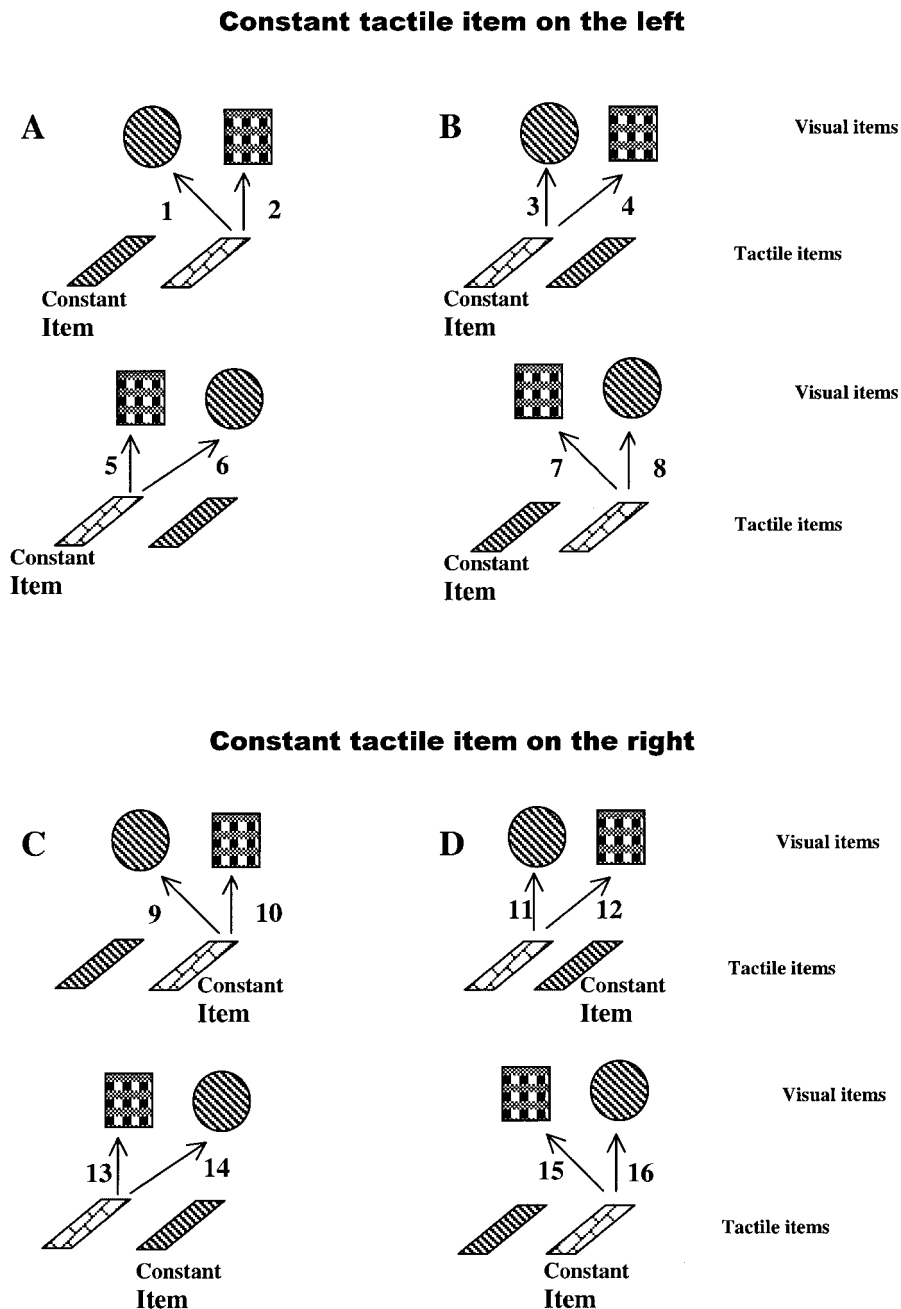

Figure 2. All possible cross-modal illusory conjunctions (represented by the arrows) in Experiment 2. Visual and tactile stimuli with an identical pattern represent stimuli in the experiment with identical texture. The numbers represent the error types (see the *Method* section of Experiment 2 for a full description). A and C: Identical visual and tactile textures are in the same hemisphere. B and D: Identical visual and tactile textures are in opposite hemispheres.

do not allocate full attention to the felt textures (we tested this in Experiment 4). Participants may tend to attend to the constant texture across trials, and this may be most likely when it is on the right and so felt by the preferred hand of most participants. On these trials, little attention may be paid to the left texture, allowing it to enter into an illusory relationship with the visual stimuli also presented under conditions of reduced attention. Consistent with

this, there tended to be particularly large numbers of tactile ICs when the varied texture was on the left (Errors 11 and 13). Note that these errors were on the stimulus typically reported first and so were most unlikely to reflect memory errors. Whether this attentional account is correct awaits further research. For now, the important contribution of Experiment 2 is demonstrating converging evidence for a perceptual contribution to cross-modal ICs.

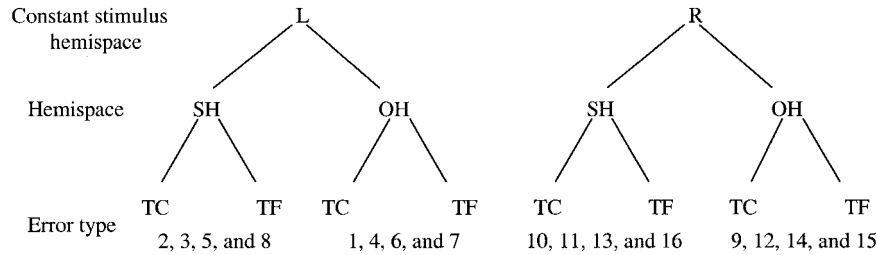

Figure 3. Schematic representation of the mixed-design analysis of variance in Experiment 2. L = left; R = right; SH = same hemisphere; OH = opposite hemisphere; TC = tactile conjunction; TF = texture feature. The numbers in the bottom row represent the tactile conjunction error types shown in Figure 2.

### Experiment 3: Forced-Choice Performance

Experiment 3 set out to provide a further test of the memorial account of cross-modal ICs. In this study, instead of having participants report all the information they could about the visual displays, we gave them a forced-choice decision: Did we present a particular visual shape–texture combination? If memorial processes are responsible for the cross-modal ICs (i.e., participants remember the features they saw but cannot remember which were conjoined together), then these errors should be minimized under forced-choice conditions. In the previous two experiments, in which the participants had to fully report the visual features, they might lose feature and conjunction information while they were responding, and this might have been the cause of ICs. If cross-modal ICs are perceptual in origin, then they should occur even when forced-choice decisions are used (see McClelland & Johnston, 1977; Reicher, 1969; and Wheeler, 1970, for examples of the adoption of forced-choice procedures to minimize memory and guessing effects in the study of the word superiority effect; see Treisman & Schmidt, 1982, Experiments II and III, for an application to the study of ICs).

Table 2  
Percentages of Tactile→Visual Conjunction and Texture Feature Errors in Experiment 2, According to Whether Visual and Tactile Items Fell in the Same Hemisphere and According to the Position of the Constant Tactile Stimulus

Error	Hemisphere (and error types)	
	Same (2, 3, 5, and 8)	Opposite (1, 4, 6, and 7)
Constant tactile item on the left		
Tactile→visual conj.	6.3	4.9
Texture feature	5.0	2.4
Error	Hemisphere (and error types)	
	Same (10, 11, 13, and 16)	Opposite (9, 12, 14, and 15)
Constant tactile item on the right		
Tactile→visual conj.	9.9	4.2
Texture feature	2.8	2.5

Note. Error types are illustrated in Figure 2. conj. = conjunction.

### Method

**Participants.** A total of 16 participants from The University of Birmingham took part in the experiment. Their ages fell between 18 and 29 years. All participants had normal or corrected-to-normal vision and normal color vision.

**Stimuli.** The stimuli were the same used in Experiment 1. However, to generate errors under forced-choice conditions, we presented four visual stimuli on each trial. The sizes of the stimuli were smaller than in the previous experiments (4 × 4-cm square, 4-cm-diameter circle, and 5.2 × 4-cm triangle). Shapes were positioned at each corner of an imaginary square (7.2 × 7.2 cm) located at the center of the display. One additional texture (bubble wrap) was added to the set of visual textures used in the previous experiment (artificial fur, a Lego brick, carpet, and beans).

**Procedure.** On each trial, the tactile texture was never the same as one of the visual textures (and it was never bubble wrap). All the visual shapes were presented on each trial (square, circle, and triangle), and, therefore, on each trial, two visual stimuli had the same shape. Two visual stimuli had bubble wrap texture, and the other two visual stimuli had two other textures.

A visual target was present on half of the trials, in any of the four positions. The target was characterized by a specific shape and texture. Its shape was always a square, and its texture could be any of the visual textures, except bubble wrap. The target texture was balanced across participants. For each participant, the target remained the same for the whole experiment. The target never had both the shape and the texture in common with any other stimulus.

The participants were instructed to touch the tactile stimulus as soon as the fixation cross appeared. This ensured that participants were touching the texture when the visual stimuli were presented. There were two tasks: First, participants had to name the orientation of the tactile stimulus (either vertical or horizontal), and then they had to say whether a prespecified target was present on the display. When the participants made false negative errors (i.e., the answer was “target not present” when the target was present), they were asked what shapes and textures they saw. The 108 trials in which the target was not present were composed as follows. On 42 trials, the tactile stimulus had the target texture, but none of the visual items had it. On 42 other trials, none of the stimuli (neither the visual nor the tactile) had the target texture. On the remaining 24 trials, one visual stimulus had the target texture (but not the shape), whereas the tactile stimulus did not have the target texture.

Each participant completed four blocks of 54 trials each. The exposure duration for the visual stimuli was set for individual participants, after a practice session, so that they achieved an accuracy score of between 65% and 90% correct. If, at the end of each block, the score was not in the range required, the duration of the following block was changed. The average duration, across participants, was 75 ms (range = 45–120 ms). A mask followed the visual stimuli (for 75 ms).

## Results and Discussion

The results of Experiment 3 are shown in Table 3. They are divided into two different conditions, for target-present and target-absent trials. When participants missed a target (on a target-present trial), they were asked what they saw on the display. The participants were never able to report all four visual stimuli on a trial. Every incorrect report of a visual stimulus was considered as an error, and, therefore, more than one error could occur on a target-present trial. Four kinds of error were possible to be made to the visual stimuli. A *miss* occurred when the participants failed to report both the shape and the texture of the target stimulus. A tactile→visual conjunction error was made when the reported visual texture of either the target or any other visual stimulus presented was actually the texture of the tactile stimulus. A texture feature error was made when the reported texture of any visual stimulus was not presented at all on that trial. A *shape error* was made when any of the visual textures presented was reported with the wrong shape. In the target-absent condition, incorrect detections of the target were classified according to the visual and tactile textures presented on the particular trial (note that all the shapes were always present). Three kinds of error could be made. A tactile→visual conjunction error was made when only the tactile stimulus had the target texture. A texture feature error was made when neither the tactile nor any visual stimulus had the target texture. A shape error was made when a visual stimulus had the same texture but a different shape to the target.

For both target-present and target-absent trials, tactile→visual conjunction errors were more frequent than texture feature errors (2.60% vs. 1.74% in the target-present condition and 8.28% vs. 6.60% in the target-absent condition). The data were analyzed with a paired-samples *t* test for each condition. In the target-present condition, the difference between tactile→visual conjunction and texture feature errors approached significance,  $t(15) = 1.89$ ,  $p = .08$ ; however, the difference between those errors was significant in the target-absent condition,  $t(15) = 2.30$ ,  $p = .04$ .<sup>1</sup> The data provide evidence again for cross-modal ICs, even though a forced-choice response mode was used here to attempt to minimize effects of memory on report. Indeed, if anything, cross-modal ICs were more pronounced on target-absent than on target-present trials (on target-present trials, ICs were produced by participants reporting a particular shape–tactile texture pairing, after reporting that the target was absent; on target-absent trials, ICs were generated by participants reporting incorrectly that a probed shape–tactile texture pairing was present). This again supports the argument that cross-modal ICs were perceptual rather than being purely gener-

ated from memory errors because the memory load should be greater on target-present trials (when a full report response was made).

## Experiment 4: Effect of Attention on Cross-Modal ICs

In Experiment 1, in which cross-modal ICs were found, the participants were presented with two visual stimuli and one tactile stimulus. The task was to report, first, the orientation of the tactile stimulus and then the shape and texture of each visual stimulus. We argued that cross-modal binding arose because attention was not paid to the tactile texture, allowing it to be available for binding with information in other modalities. It follows that paying more attention to the tactile texture (e.g., if participants are asked to name it) might cause a decrease in cross-modal ICs because attention to the tactile texture (for report) may help to bind it to its modality. On a memory account, however, the opposite might be expected. This is because the report load was increased when responses were required to more attributes, so more response confusions (assignment of the tactile texture to vision) may be predicted. To test this, in Experiment 4 we presented participants with two visual stimuli and one tactile stimulus, as in Experiment 1. However, unlike in Experiment 1, the participants also had to report the tactile texture, along with the tactile orientation, visual shapes, and textures. This experiment not only gave us the opportunity to test whether cross-modal ICs decreased when the participants were asked to report the tactile texture but also created the circumstances to see whether cross-modal ICs of the visual texture to the tactile stimulus were possible (in the previous experiments, we tested for ICs of the tactile texture to the visual stimulus).<sup>2</sup>

## Method

**Participants.** A total of 16 students of The University of Birmingham were tested. Their ages fell between 18 and 24 years. All participants had normal or corrected-to-normal vision and normal color vision.

**Stimuli.** The stimuli were identical to those used in Experiment 1.

**Procedure.** The procedure of this experiment was identical to the procedure of Experiment 1. Participants were simultaneously presented with two visual stimuli and one tactile stimulus (which could not be seen). The first task was now to report not only the tactile orientation but also the tactile texture. The second task remained the same (i.e., to report shape and texture of the two visual stimuli).

A fixation cross was first presented at the center of the screen for 750 ms; the visual stimuli followed, for an average duration of 239 ms; and, finally, a mask was presented for 75 ms. Each participant underwent a practice session (of a variable number of trials), followed by two blocks of 72 trials each.

Table 3  
Mean Percentages for Each Response Category in Experiment 3

Responses	Target present	Target absent
Correct	73.50	78.82
Target miss	13.77	
Tactile→visual conjunction	2.60	8.28
Texture feature	1.74	6.60
Shape error	12.67	6.31

*Note.* Data were divided according to whether the target stimulus was presented.

<sup>1</sup> Putting the target-present and target-absent data together in an ANOVA, with target presence and error type (tactile conjunction and texture feature errors) as factors, we found that there was a main effect of error type,  $F(15) = 7.35$ ,  $p = .02$ , and no interaction,  $F(15) = 1.10$ ,  $p = .31$ .

<sup>2</sup> Unfortunately, in practice, there was good report of the tactile stimulus, precluding any possible identification of visual texture errors to tactile stimuli.

## Results and Discussion

The trials were divided into two conditions: the different texture condition, in which the tactile texture was different from the two visual textures, and the same texture condition, in which the tactile texture was the same as one of the visual textures. The two visual textures were always different from each other, in both conditions. In the same texture condition, tactile→visual conjunction errors could not be scored because they could not be distinguished from correct responses. Therefore, the different texture condition was critical for evaluating cross-modal ICs. The results are shown in Table 4. Like in all the previous experiments, to assess whether cross-modal ICs occurred, tactile→visual conjunction errors were compared with texture feature errors. Tactile→visual conjunction errors (5.64%) were slightly more frequent than texture feature errors (4.60%), but this difference did not approach significance,  $t(15) = 1.11, p = .28$ . It follows that any tactile→visual conjunction errors here can be considered, like texture feature errors, to be a result of guessing or misperception of features and not as a result of imperfect binding. In Experiment 1, which was identical to Experiment 4, except that the participants did not have to report the tactile texture, participants did make cross-modal ICs. In fact, although the percentage of feature errors was about the same as in Experiment 4 (4.58% in Experiment 1), the percentage of conjunction errors was much higher in Experiment 1 (8.7%) than in Experiment 4. We performed a between-subjects ANOVA, in which the difference between conjunction and feature errors in Experiment 1 was compared with the difference between the same errors in Experiment 4. It showed that there was a significant difference between the two experiments,  $F(1, 30) = 4.95, p = .03$ . The difference between the two types of error was increased in Experiment 1. In Experiment 4, reporting the tactile texture forced the participants to pay more attention to it, and this appears to be

critical in promoting a better binding of the tactile texture to its location. These results agree with FIT (Treisman, 1998; Treisman & Gelade, 1980), according to which attention facilitates correct binding, because it allows the recovery of spatial information relating to each feature.

These results also give further support to our claim, previously discussed, that cross-modal ICs develop at perceptual preattentive stages and are not a mere result of memory failures (see Experiments 2 and 3). In fact, if compared with Experiment 1, Experiment 4 is more demanding in terms of memory because there is an additional feature to report—the tactile texture. If, in Experiment 1, cross-modal ICs were caused by the difficulty of remembering which features belonged to which stimulus (given that all the features were correctly perceived), in Experiment 4, the frequency of cross-modal ICs should have increased. However, the opposite happened: No cross-modal ICs occurred. In a memorial account, there is no reason why reporting the tactile texture would decrease the probability of making ICs errors. Therefore, these results, with the findings of Experiments 2 and 3, strongly support a perceptual account of cross-modal ICs.

This experiment also showed that the perception and report of the tactile texture were very accurate. The average accuracy was 99.6%, and only 4 out of 16 participants made incorrect reports of the tactile texture. Consequently, it was not possible to test whether cross-modal ICs of the visual texture to the tactile stimulus occurred. Note too that, in the study, participants were asked to report on the visual as well as the tactile textures. This may have, in any case, reduced the frequency of ICs. ICs of visual textures to tactile stimuli were assessed more stringently in Experiment 6.

### Experiment 5: Cross-Modal ICs in a Patient With Parietal Damage

There is neuropsychological evidence that the parietal lobe is involved in binding visual features. For example, patients with unilateral parietal damage may identify the features of multiple stimuli presented on the contralesional side, but they can fail to bind the features correctly (Cohen & Rafal, 1991), showing an abnormally high frequency of visual ICs. In a similar manner, high rates of visual ICs can be formed under free-viewing conditions in patients with bilateral parietal damage (Friedman-Hill, Robertson, & Treisman, 1995; Humphreys et al., 2000). In Experiment 5, we tested a patient with a left parietal lobe lesion, M.H., to assess whether parietal damage is also associated with binding stimuli to their input modality. Patients with parietal damage can also show evidence of cross-modal interference, with their attention to a contralesional stimulus in one modality being affected by an ipsilesional cue presented in another modality (e.g., Farah, Wong, Monheit, & Morrow, 1989; Mattingley et al., 1997). These last results suggest that parietal damage may be associated with a lack of sensitivity to the modality of origin of a given stimulus.

M.H. was tested under two different conditions: In the first condition (the *perception condition*), the stimuli and procedure were the same used in Experiment 1 for normal participants, except that the exposure durations were considerably longer. This allowed us to examine whether M.H. showed a frequency of

Table 4  
Percentages of Responses in Experiment 4, According to Whether the Tactile Texture Was the Same as or Different From One of the Visual Textures

Responses	Texture	
	Different	Same
Correct	72.92	77.08
One item incorrect		
Tactile→visual conj.	5.64	
Texture feature	4.60	9.46
Shape feature	8.33	7.38
Texture and shape feature	1.48	2.34
Tactile→visual conj. and shape feature	1.82	
Two items incorrect		
Visual conj.	0.95	0.95
Visual conj. and texture feature	0.52	0.78
Visual conj. and shape feature	0.35	0.87
One tactile→visual conj., one texture feature	0.26	
One tactile→visual conj., one shape feature	0.35	
One tactile→visual conj., one texture and shape feature	0.43	
One texture feature, one shape feature	0.35	0.43
One shape feature, one texture and shape feature	0.69	0.26
Other errors	1.31	0.45

Note. conj. = conjunction.

cross-modal ICs higher than normal at these durations.<sup>3</sup> From this, we can judge whether the parietal lobe is involved not only in visual feature binding but also in binding features to their modality. In the second condition (the *memory condition*), the visual and tactile stimuli were presented in sequence rather than simultaneously: The visual stimuli were presented first; then, after about 750 ms, the tactile stimulus was presented. The duration of the interval between the presentation of the visual stimuli and the tactile stimulus was selected in an attempt to avoid interference between tactile perception and visual perception processes. If ICs arose through memory failure, then ICs should increase in the memory condition, relative to the perception condition, because M.H. must maintain the visual stimuli for a longer amount of time in the memory condition. On the other hand, there is more likely to be simultaneous encoding of the visual and tactile textures in the perception condition. In addition, the perception condition will increase the attentional load of the task, relative to the memory condition, because two textures need to be encoded simultaneously in the former but not the latter case (cf. Duncan, 1980). If cross-modal ICs arise under conditions of simultaneous encoding, attention load, or both, then they should be more frequent in the perception condition than the memory condition.

### Case Report

M.H. suffered an anoxic incident when he was aged 42. A computerized tomography scan revealed increased signal in the left posterior parietal region and, to a lesser extent, in the left frontal region. Increased signal was also reported in the lentiform nucleus bilaterally, slightly more pronounced on the left than on the right, and in the heads of the caudate nuclei bilaterally. Following the incident, M.H. had difficulties in all activities of everyday life. For example, he was unable to dress or to coordinate properly his fork and knife when eating. Writing was also impaired. In a visual neuropsychological assessment of his visual processing, M.H.'s performance was normal on object-recognition tests; however, his performance was very poor on space-perception tests. For instance, on the Visual Object and Space Perception Battery (Warrington & James, 1991) taken in 1999, M.H. performed within the control range on all the object perception tests: On the first test (shape detection), for which M.H. was required to indicate whether a white *X* was present against a background of white and black noise, he scored 19 out of 20; he scored 20 out of 20 on a test requiring one to identify black uppercase letters that have been degraded by white noise; he also performed well in all the tests assessing object recognition (silhouettes, 19 out of 20; object decision, 19 out of 20; progressive silhouettes, 9 out of 10). M.H.'s performance, however, was impaired for most of the space-perception tests. On a dot-counting task, for which he had to count the number of black dots in random arrays of 5–9 dots, he scored 4 out of 10; on another test, for which M.H. had to discriminate which of two squares contained a dot in the center (as opposed to slightly off center), he scored 19 out of 20. When asked to identify the location of a dot in a square by choosing a numbered location in another square that corresponded to the same location, M.H. scored 4 out of 10; finally, M.H.'s performance was also poor when asked to count the number of cubes in drawings of three-dimensional cubes, for which he scored 4 out of 10.

In a star and letter cancellation test, from the Behavioural Inattention Test (Wilson & Cockburn, 1987), M.H. did not show evidence of neglect. However, there was evidence of extinction. For example, with letters presented for 200 ms to the left and right of fixation, M.H. scored 20 out of 20 for single items in his left field, 19 out of 20 for single items in his right field, but only 8 out of 20 on bilateral, two-letters trials. On all bilateral trials, he identified the left- but not the right-side letter. There were also indications of tactile extinction (a single brush stroke to the left or right hand, or both). However, under the exposure durations used in Experiment 5 (e.g., 500 ms and 850 ms, in the perception and memory conditions), it is unlikely that extinction took place. Overall, M.H.'s deficits suggest that the dorsal visual pathway, which is implicated in the processing of spatial characteristics of the visual stimuli, has been compromised, whereas the ventral visual pathway, which is implicated in the processing of the features relevant to the identification of the objects, is relatively intact (Riddoch, 2002).

### Method

*Stimuli.* The stimuli were the same as in Experiment 1.

*Procedure.* The experiment was run in two different conditions: the perception condition and the memory condition. The procedure of the perception condition was the same as that used in Experiment 1, except that the duration of the visual stimuli was 500 ms, and no mask was presented. These presentation conditions are outside the range used with any of the control participants (see Experiment 1). Control participants do not make IC errors in our conditions at these exposures. Also, only horizontally aligned visual stimuli were presented. The procedure of the memory condition was slightly different. After the first two displays appeared (the fixation cross and the visual stimuli), a blank screen followed for 750 ms, and then a display with a green cross was displayed for 1 s. M.H. was told to touch the tactile stimulus as soon as he saw the green cross. M.H. had first to name the orientation of the tactile stimulus and then the shape and texture of the two visual stimuli. The average duration of the visual stimuli was 850 ms. M.H. completed 16 blocks of 72 trials each in the perception condition and 8 blocks in the memory condition.

### Results and Discussion

The percentage errors made by M.H. are shown in Table 5. In the perception condition, the frequency of tactile→visual conjunction errors (9.54%) was higher than the frequency of texture feature errors (4.42%). The ratio of tactile ICs to feature errors was higher than the mean ratio for control participants obtained with shorter presentation conditions, in Experiment 1, although it fell within two standard deviations of that mean. In the memory condition, the average numbers of tactile→visual conjunction errors and texture feature errors (2.08% and 2.60%) were very similar. Performance was analyzed by treating each trial block as an independent subject, using a separate analysis for the two conditions. The analyses showed that although the difference between tactile→visual conjunction and texture feature errors was significant in the perception condition,  $t(15) = 2.74, p = .02$ , the difference between those errors was not significant in the memory condition,  $t(7) = 0.02, p = .98$ .

<sup>3</sup> Note that minimal ICs or feature errors would be made by controls at the durations used here.

Table 5  
*Percentages of Responses Given by M.H. in Experiment 5, According to Whether the Tactile Texture Was the Same as or Different From One of the Visual Textures*

Responses	Perception condition		Memory condition	
	Different texture	Same texture	Different texture	Same texture
Correct	50.88	50.74	38.02	37.50
One item incorrect				
Tactile→visual conjunction	9.54		2.08	
Texture feature	4.42	13.32	2.60	5.96
Shape feature	11.66	17.76	15.10	20.24
Tactile→visual conjunction and shape feature	2.47		1.56	
Texture and shape feature	1.94	4.86	3.65	2.98
Shape miss	1.24	0.63	2.08	1.19
Texture miss	0.71	1.27	1.56	1.19
Two items incorrect				
Visual conjunction	1.24	2.96	14.58	10.71
Visual conjunction and texture feature	1.06	1.48	2.60	2.98
Visual conjunction and shape feature	0.53	0.42	8.85	8.93
Only one item reported	4.77	4.44	4.08	4.17
Other errors	9.54	2.12	5.24	4.16

*Note.* In the perception condition, tactile and visual stimuli were presented simultaneously. In the memory condition, the tactile stimulus was presented about 750 ms after the presentation of the visual stimuli.

As M.H. has a left hemisphere lesion, we examined whether, in the perception condition, the frequency of cross-modal ICs was higher on the right visual stimulus than on the left one. On the left visual stimulus, M.H. made 2.83% of tactile→visual conjunction errors and 1.59% of texture feature errors. On the right visual stimulus, the percentages were 6.71% and 2.83%, respectively. The data were analyzed with an ANOVA with the factors visual stimulus (left and right) and error. The interaction between the two factors was not significant,  $F(1, 15) = 1.40, p = .25$ .

M.H. made reliably more cross-modal ICs than visual texture feature errors, even though the stimuli were presented for substantially longer durations than those used for the control participants in Experiment 1 (M.H.'s durations were more than doubled relative to controls and more than four standard deviations from the mean of the controls). This suggests that, following parietal damage, a prolonged period is required to bind a stimulus to its modality. In addition, the ICs occurred in the perception condition (when the visual and tactile stimuli were presented at the same time) but not in the memory condition (in which the tactile stimuli were presented after the visual stimuli). This last result is of some importance because the load on memory for reporting the visual features should have been increased in the memory relative to the perception condition. We found the opposite. This is consistent with the cross-modal ICs being most likely to occur when there is simultaneous perception of the stimuli in the different modalities and/or under conditions of increased attentional (rather than memory) load. Damage to the parietal lobe, in M.H.'s case, seems to delay the ability to assign the textures to their input modality. Hence, M.H. shows cross-modal ICs at durations not found to be effective with control participants. This is an effect on perception, not memory.

#### Experiment 6: Cross-Modal ICs of the Visual Texture to the Tactile Stimulus

Experiments on cross-modal influences on attentional orienting (e.g., Driver & Spence, 1998a, 1998b) have shown that tactile and

visual cues can influence attention in similar ways. Thus, a visual cue can affect the orientation of tactile attention in the same way as a tactile cue can affect the orientation of visual attention (Spence & Driver, 1998). In Experiments 1–4, we found that cross-modal ICs of the tactile texture to the tactile stimulus were possible. The aim of the present experiment was to investigate whether a symmetry also exists for cross-modal ICs. This would require proving that ICs of the visual texture to the tactile stimulus are possible.

In Experiment 4, the participants were presented with two visual stimuli and one tactile stimulus, and the tasks were to report the orientation and texture of the tactile stimulus, as well as the shapes and textures of the visual stimuli. We found that the accuracy in reporting the tactile texture was very high. Indeed, most of the participants did not make any errors when reporting the tactile texture, and, for that reason, it was not possible to assess whether cross-modal ICs occurred from the visual texture to the tactile stimulus. In Experiment 6, we made the task more difficult so as to obtain more incorrect reports of the tactile texture and, in so doing, we sought to maximize the opportunity for cross-modal ICs on the tactile stimulus. Also, to minimize attention to visual textures, we no longer required report of this information. Here, then, the participants were presented with two visual stimuli and two tactile stimuli, and their task was to report (a) the two visual shapes, (b) an answer regarding whether the orientation of the tactile stimuli was the same or different, and (c) the two tactile textures.

#### Method

*Participants.* A total of 16 students of The University of Birmingham were tested. Their ages fell between 18 and 22 years. All participants had normal or corrected-to-normal vision and normal color vision.

*Stimuli.* The visual stimuli were identical to those used in Experiment 1. The tactile stimuli were bars made of four different materials (carpet, fur,

beans, and a Lego brick), but their size was slightly smaller (about  $3 \times 7$  cm) than in the previous experiments.

**Procedure.** On each trial, participants were presented with two visual and two tactile stimuli. One of the tactile textures was identical to one of the visual textures, so that on each trial, three of the four textures were presented. The visual stimuli were preceded by a fixation cross, presented at the center of the screen, and were followed by a mask. The two tactile stimuli were placed on the table, in front of the participants, next to each other. They had either the same or different orientation. Also, a tactile mask was used. This was a board ( $43 \text{ cm} \times 35 \text{ cm}$ ) whose surface was tiled with fragments of the same materials used to make the tactile stimuli, randomly placed. The tactile mask was placed on the table in front of the participants during the whole experiment, and on each trial, the tactile stimuli were placed on it. Each participant was instructed to look at the screen and touch the two tactile stimuli as soon as the fixation cross appeared. They were asked to touch the stimuli for the time strictly necessary to recognize their relative orientation and textures. The left stimulus was touched with the left hand and the right stimulus was touched with the right hand. Immediately after that, the participants quickly touched the mask. They were asked not to rest their hands on the board between trials.

The tasks of the participants were to report the two visual shapes, then they had to say whether the orientation of the two tactile stimuli were the same or different. Finally, they reported the two tactile textures.

Participants were presented with two blocks of 72 trials each. These were preceded by a preliminary session during which the participants were given detailed instructions on how to perform each task and a practice session of a variable number of trials. Once the participants felt confident and performed the tasks correctly and in the right order, the experimental session started.

The fixation cross was presented for 750 ms, the visual stimuli were presented for 75 ms (however, to one of the participants, who found it very difficult to recognize the visual shapes, they were presented for 150 ms), and the visual mask was presented for 60 ms.

## Results and Discussion

With the presentation of two tactile stimuli, the task of reporting the tactile textures was made more difficult. The average accuracy was 91.3% (ranging from 69.4% to 99.3%). Errors occurred when at least one of the tactile textures was reported incorrectly. Visual→tactile conjunction errors occurred when one of the reported tactile textures was actually a visual texture presented on that trial. Texture feature errors occurred when one of the reported tactile textures was not presented on that trial. Note that, on each trial, one tactile texture was the same as one visual texture, with the identical textures being on the same side on half of the trials. Once again, cross-modal ICs were assessed by comparing the frequency of conjunction errors with the frequency of feature errors. The average frequency of conjunction errors (5.3%) was significantly higher than the frequency of feature errors (3.7%),  $t(15) = 3.08, p < .01$ . These results indicate that cross-modal ICs of the visual texture to the tactile stimulus can occur as can ICs of the tactile texture to a visual stimulus. We compared the frequencies of conjunction and feature errors of this experiment with those of Experiment 2 (conjunction errors = 6.3%; feature errors = 3.2%). Also, in that experiment, two visual stimuli and two tactile stimuli were presented, but the participants had to report the two visual textures and not to report the two tactile textures, and, therefore, cross-modal ICs were made to the visual stimuli. We performed a between-subjects ANOVA test and found that there was no significant difference between the experiments in the number of conjunction errors relative to feature errors,  $F(1, 34) =$

1.65,  $p = .21$ , whereas the overall effect of error type was significant,  $F(1, 34) = 17.32, p < .01$ . This suggests that, at some stage, when attention is not focused on the stimuli, not only is there imprecise spatial coding of both tactile and visual features (as also suggested by FIT for visual stimulus processing) but also that the same features are not well linked to their modality of origin. In that way, tactile features can be eventually identified as visual features or visual features identified as tactile features and, in both cases, bound with the incorrect modality. Previous studies (e.g., Lederman, Thorne, & Jones, 1986) described in the literature have shown that, in many cases, in tasks requiring texture judgments, the tactile modality can dominate over the visual modality. In our experiments, we have shown that there is a symmetry between cross-modal ICs to the visual stimuli and cross-modal ICs to the tactile stimuli and that the two modalities can be equally balanced.

As in Experiment 2, we could also test here whether cross-modal ICs were more frequent between stimuli presented in the same hemisphere than between stimuli presented in opposite hemispaces. For this, the equivalent analysis to the one described in Experiment 2 was carried out. When the visual and tactile stimuli with identical textures were in the same hemisphere (see Figure 4), cross-modal conjunction errors on the tactile stimulus whose texture matched that of the visual stimulus were possible from the visual element in the opposite hemisphere (in Figure 4, Error Types 1 and 6), whereas conjunction errors on the tactile stimulus with a different texture were possible only from the visual stimulus in the same hemisphere (Error Types 2 and 5). When visual and tactile stimuli with identical textures were in opposite hemispaces, conjunction errors on the tactile stimulus with identical texture were possible only from the visual stimulus in the same hemisphere (Error Types 4 and 7), whereas conjunction errors on the tactile stimulus with a different texture were possible only from the visual stimulus in the opposite hemisphere (Error Types 3 and 8).

Table 6 shows the percentage of visual–tactile conjunction errors that occurred between stimuli in either the same hemisphere or in opposite hemispaces and the relative percentages of feature errors. The difference between conjunction and feature errors was numerically bigger in the same-hemisphere condition than in the opposite-hemisphere condition, but, the interaction between the types of error and the hemisphere was not statistically significant,  $F(1, 15) = 0.58, p = .46$ .

In Experiment 2, we did find a reliable effect of hemisphere: Cross-modal ICs to the visual stimulus were more frequent from tactile stimuli in the same hemisphere as the visual stimulus, relative to when tactile stimuli appeared in the opposite hemisphere. It is not clear why the same effect did not occur here for visual–tactile ICs. Two possibilities are as follows. One is that hemisphere is a more salient attribute of tactile than visual representations, especially when (as here) different hands felt the texture in the left and right hemispaces. The tactile representation of the world may need to be coded with respect to body space because this captures the sensory information available directly to that modality. Visual stimuli may be coded in a number of different frames (environmental, head centered), reflecting the direct sensory and stimulus attributes for this modality. Hemisphere may not be a salient property of this visual representation. A second possibility relates to a difference in the experimental procedure in Experiments 2 and 6. In Experiment 2, there was always one constant tactile texture. In Experiment 6, both tactile textures and the visual textures could

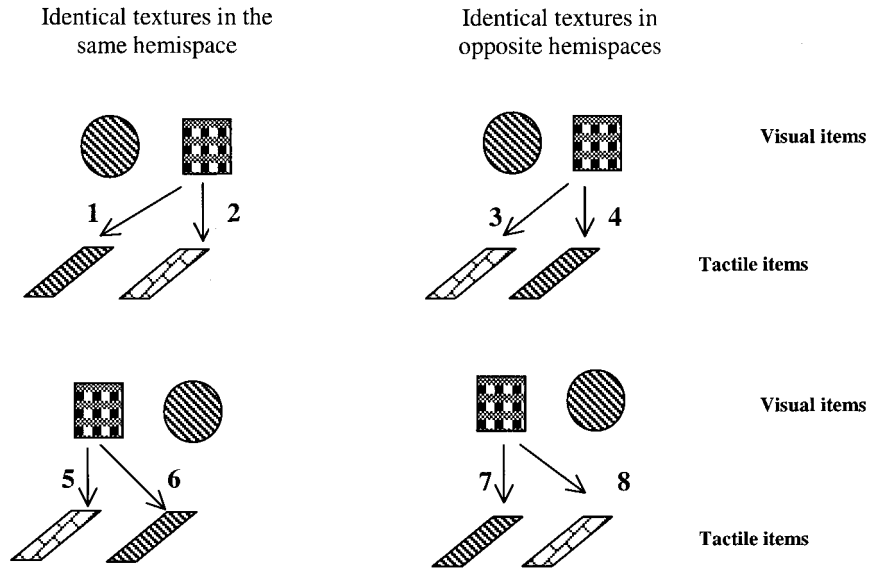

Figure 4. All possible allocations of the visual and tactile stimuli in Experiment 6. Visual and tactile stimuli with identical patterns represent stimuli in the experiment with identical textures. Arrows represent all possible conjunction errors of the visual texture to the tactile stimulus.

vary from trial to trial, and this might have led to a more even distribution of attention across both left and right hemispaces, reducing any effects of hemispace on performance. These possibilities should be tested in future experiments.

### A Measurement Model of Cross-Modal ICs

In all the experiments described above, we tested whether the frequency of conjunction errors was higher than the frequency of texture feature errors, to evaluate whether cross-modal ICs occurred. This criterion has been widely used in research on visual ICs: The feature error rate is taken as a measure of guessing, and when the conjunction error rate is higher than that, then ICs are assumed to occur (e.g., Khurana, 1998; Treisman, 1988; Treisman & Schmidt, 1982; see also Cohen & Ivry, 1989; Cohen & Rafal, 1991, for a similar approach using ratios of conjunction-to-feature errors). In this section, we describe a multinomial model we have developed to test the presence of cross-modal ICs in a more analytical fashion. This model has been inspired by other models

previously developed by Prinzmetal and colleagues (Ashby, Prinzmetal, Ivry, & Maddox, 1996; Prinzmetal, Henderson, & Ivry, 1995; Prinzmetal, Ivry, Beck, & Shimizu, 2002; see also Donk, 1999). According to these authors, a formal approach “forces one to make assumptions explicit” but also “permits the estimation of underlying psychological parameters from overt behavior” (Ashby et al., 1996, p. 166).

We used our multinomial model to fit the data of Experiments 1 (tactile→visual ICs) and 6 (visual→tactile ICs).

### The Model

We used a probabilistic model that tried to capture the most important features of the binding process in multimodal (visual→tactile) perception. The model was based on a small number of assumptions. These are described below together, along with a justification for them.

*Independent perception and binding of shape and texture.* We assumed that the process of perceiving and binding the shape-related features of stimuli was statistically independent from the perception and binding of texture-related features. We also assumed that the perception of features (be they shapes or textures) and their binding are statistically independent processes (note that we made this assumptions for our specific case, and we do not claim that it is generally true, for example, within a modality).

*Independent perception of the shapes of different (visual) stimuli.* Performance in our experiments was averaged across the left–right and up–down locations of stimuli (and participants were asked to report the stimuli in whatever order they liked). Consequently, rather than having separate parameters for each location, the model included only one parameter to describe the reliability of shape perception:  $\beta_{VS}$ .  $\beta_{VS}$  represents the probability that each visual shape is correctly identified (but not necessarily correctly bound) by the observer. So, for example, if two visual shapes were

Table 6  
Percentages of Visual→Tactile Conjunction and Texture Feature Errors in Experiment 6, According to Whether Visual and Tactile Items Fell in the Same or in the Opposite Hemispace

Error	Hemispace (and error types)	
	Same (2, 4, 5, and 7)	Opposite (1, 3, 6, and 8)
Visual→tactile conjunction	6.0	4.7
Texture feature	3.9	3.5

Note. Error types are illustrated in Figure 4.

presented, the probability that they were both correctly identified is  $\beta VS \times \beta VS$ , the probability that one of them was incorrectly identified is  $2 \times \beta VS \times (1 - \beta VS)$ , and the probability that both of them were not perceived is  $(1 - \beta VS)(1 - \beta VS)$ .

*Independent perception of the texture of different (visual) stimuli.* A similar assumption was made for the perception of textures. Again, a single parameter was adopted,  $\beta VT$ , which represents the probability that each visual texture is correctly identified by the observer.

*Infallible perception of tactile texture.* Because participants were exposed to the textures of tactile stimuli for a relatively long time, we assumed that their sensory system perceived such textures with 100% reliability. This assumption is also corroborated by the results of Experiment 5, in which tactile textures were reported in addition to the visual shapes and textures. Accuracy in this study was very high with the tactile texture reported correctly on an average 99.6% of the trials. As a result, and to make the model as simple as possible, we did not include a parameter to represent the reliability of tactile-texture perception.

*Binding features.* We assumed that the binding process for a group of features can be modeled as follows. Features that have not been perceived do not take part in the process. Each perceived feature has a probability,  $\alpha$ , of being correctly associated to its location. This parameter is the same for all features of a given type. So, we have an  $\alpha VS$  parameter for visual shapes, a (possibly different)  $\alpha VT$  parameter for visual textures, and an  $\alpha TT$  parameter for tactile textures. For example, the probability that two visual shapes will be correctly bound to their location is  $\alpha VS \times \alpha VS$ , whereas the probability that two visual textures and one tactile texture will be correctly bound is the product of  $\alpha VT \times \alpha VT \times \alpha TT$ .

An important component of our binding model is the specification of what happens when the binding for one or more perceived features fails. When this happens, we assume that the unbound features are randomly assigned to the available (unbound) locations. So, for example, if two visual textures and one tactile texture are presented but only one of them is correctly bound, the remaining two features are assigned to the remaining two locations randomly. As a result, in this example, binding is still correct for 50% of the cases. It is obvious that when only one feature and one location are unbound, the binding process is still 100% correct. (This may be seen as a sort of error correction mechanism.)

*Guessing.* When one or more features have not been perceived, the participants were asked to report what they think the feature or features might have been or to guess, if they have no idea. This guessing would be initially expected to produce random answers. However, during the practice sessions and, later, during the experimental sessions, the participants may start to get used to the regularities within the probability distribution of features, perhaps without being aware of the process. To model this potential bias, we assumed the worst possible scenario, that is, that the participants always guessed the not-perceived features in such a way as to maximize the probability of being correct. This is equivalent to assuming that the participants knew the exact probability distribution with which the trials were created and would make the most rational decision when they were unable to identify features. Because of this, when we optimized the model's parameters (including binding parameters, such as  $\alpha VT$  and  $\alpha TT$ ) so as to best fit the experimental data, we tended to underestimate the

probabilities of all types of errors, including those indicating the presence of ICs. Consequently, if the resulting model indicates the presence of ICs, we can be certain that this is not a result of sophisticated guessing.

As an example, consider the case in Experiment 1 in which a participant has (a) correctly perceived and bound the shape features of two visual stimuli, (b) correctly perceived and bound the texture of one of them, and (c) correctly bound the texture of the tactile stimulus (which, as we mentioned above, is always correctly registered). So, the texture of the second visual stimulus has not been identified (and cannot be bound). In this situation, a rational observer (fully aware of the statistical regularities in the trials) will behave as follows.

1. If the perceived visual texture is the same as the tactile texture, A, then the participant knows that the trial is a same-condition trial. Thus, he or she knows that the not-perceived visual texture must be any of the other three textures, B, C, or D, with equal probability, and he or she will choose one of them randomly. As a result, the participant will be correct one third of the time, whereas two thirds of the time, he or she will make a texture feature error. This situation will arise  $\frac{1}{2} \times \frac{1}{2} = \frac{1}{4}$  of the time. Therefore, over the whole experiment, we should expect this condition to contribute to  $\frac{1}{12}$  of the correct responses (CCs) and  $\frac{1}{6}$  of the responses with one stimulus reported correctly and with one feature error (CF or FC; see Table 7 for a description of all responses and an explanation of how they have been labeled).

2. On another one fourth of the cases, the participant will be presented with a same-condition trial. However, in these cases, it is the not-perceived stimulus that has the same texture, A, as the tactile stimulus. Therefore, the participant cannot infer whether the trial is a same- or a different-condition trial, so the participant will behave as he or she does in the different texture condition, described below.

3. In the final half of the cases, the participant will be presented with a different-condition trial. In this case, the participant knows that the texture of the perceived visual stimulus, A, is different from the texture of the tactile stimulus, B, but there is no way of knowing whether the trial comes from a same- or a different-condition trial (because one visual texture is not perceived). So, the participant can try only to guess. Suppose that the guess is B. Then the participant has a one fourth probability of being correct. This is because he or she will be correct in all cases listed under 2 above. If, instead, the participant says C (or D), he or she will be incorrect for all cases under 2 while being correct in half of the cases under 3. Thus, correct responses will again occur for one fourth of the cases. Therefore, answering B, C, or D in cases in which the participant cannot identify whether the trial belongs to a same or a different texture condition leads to exactly the same error rate. Therefore, we can assume that the participant chooses randomly between the three textures. We can now calculate the type of errors this behavior will generate. In Case 2, participants will produce CCs on  $\frac{1}{4} \times \frac{1}{3} = \frac{1}{12}$  of the cases and CFs in  $\frac{1}{4} \times \frac{2}{3} = \frac{1}{6}$  of the cases. In Case 3, participants will produce CCs for  $\frac{1}{2} \times \frac{1}{3} = \frac{1}{6}$  of the cases, CTs (one stimulus reported correctly and one tactile  $\rightarrow$  visual conjunction error; see Table 7) for  $\frac{1}{2} \times \frac{1}{3} = \frac{1}{6}$  of the cases, and CFs for  $\frac{1}{2} \times \frac{1}{3} = \frac{1}{6}$  of the cases. If we add up all the contributions listed above, we obtain  $\frac{1}{12} + \frac{1}{12} + \frac{1}{6} = \frac{1}{3}$  CCs,  $\frac{1}{6} + \frac{1}{6} + \frac{1}{6} = \frac{1}{2}$  CFs, and  $\frac{1}{6}$  CTs.

Similar calculations can be performed for all cases when one or both visual features are not perceived and when one or more of the perceived features are not correctly bound to their locations. The calculations, however, are rather complex and tedious, so we do not report them here. We report only the final results of these calculations in the probability tree representing our model. This is described below.

### Probability Tree

The assumptions formulated above mean that the perception process can be modeled using an event tree. Each node in the tree (except the root node) represents the outcome of a perceptual event, whereas the label on the corresponding link represents the conditional probability that such an event will happen given the outcome of the events to the left of such node (the tree should be imagined sideways with the root to the left of the drawing and the leaves to the right). (Note that this is not a temporal relationship, but a probabilistic one: The event diagram and its probabilities effectively represent the joint probability distribution.) The leaves of the tree may be labeled in a variety of ways to represent the different interpretations we want to give to each set of outcomes. In a binomial type of experiment, one would label all the leaves as either *success* or *failure*. In a multinomial type of experiment, one might label some leaf nodes as *correct*, others as *conjunction error* or *feature error*, and so on. The probability of each sequence of events leading to a certain leaf taking place is the product of the probabilities labeling all the links from that leaf to the root of the event tree. If multiple leaves have the same label (e.g., *correct*), the total probability of the corresponding event is the sum of all the probabilities of the sequences of events leading to those leaves.

In the case in which many features need to be perceived and bound, as in our experiment, the event diagram may be very big. Just to give an idea of the size of this diagram, we show just a small portion of the diagram in Figure A1 in the Appendix. In this diagram, the small triangles represent an entire subtree, which is shown in Figure A2. The full diagram (represented in Figures A1–A6) includes up to 10 layers of nodes. In Figure A1, we show only the first four leaves. From left to right, these layers correspond to the following events: the shape of the first visual stimulus is or is not perceived correctly (Event 1), the shape of the second visual stimulus is or is not perceived correctly (Event 2), the first shape is or is not correctly bound to its location (Event 3), and the second shape is or is not correctly bound to its location (Event 4). The layers in Figure A2 represent the following events: The texture of the first visual stimulus is or is not correctly perceived (Event 5), and the texture of the second visual stimulus is or is not perceived correctly (Event 6). In each of the subtrees (Figures A3–A6, respectively), the layers represent the following events: The first texture is or is not correctly bound to its location (Event 7), the second texture is or is not correctly bound to its location (Event 8), the texture of the tactile stimulus is or is not correctly bound to its location (Event 9), and the participant guesses the identity of the texture features not correctly perceived (Event 10). Note that not all layers are present in all subtrees. For example, the guessing step is absent when all features have been correctly perceived.

In this study, we are not interested in ICs within vision but in cross-modal ICs. Because only the texture of the tactile stimulus

varies, not its shape, interference between modalities can happen only at the level of texture perception. Thus, we are really interested in determining only the parameters of the model related to visual and tactile texture perception.

Because of the independence assumptions listed in the previous sections, it is possible to simplify the model dramatically by averaging over the perception of visual shapes. That is, if we are not interested in the perception of visual shapes, we may reduce the complete event diagram to a single tree having only Layers 5–10 (note, in fact, that in the subtrees, only the texture-related outcomes are represented).

### Parameter Identification

To determine the parameters of our probabilistic model, we computed the fit of the model to the set of data obtained in Experiment 1. Using our simplifying assumptions, we included in the model only three parameters, making the problem of specifying them well posed.

The procedure to determine these parameters for each response type was the following. All the paths in the event diagram leading to a particular type of error were identified and the probability of occurrence of the related set of perceptual events was calculated (this was simply the product of all the labels encountered in the path from the root node to the given error). All such probabilities were added together to form an equation representing the total probability of producing the chosen error. When all such equations were available, we used a stochastic hill climber to fit the observed data to the total probability calculated using the model. This operated as follows. First, a random set of parameters for the model was generated. Second, the quality of fit of this random model was calculated. Third, the initial parameters were randomly perturbed and the quality of fit of the new model was recalculated. If the perturbed parameters provided a better fit, they were retained; if not, the previous parameters were restored. The process of perturbation and test was repeated until no further improvement was achieved. The quality of fit was the total sum of squared errors between the model's predictions and the observed data.

### Results

*Experiment 1.* In the model, outcomes are represented by two letters, each letter representing the response category given for each visual stimulus (all the parameters and outcomes used in the model optimization are shown in Table 7). For instance, when both visual stimuli are reported correctly, the response will be represented by CC; when a texture feature error is made to one of the two visual stimuli, the response will be either CF or FC, according to whether the error has been made on the first or second visual stimulus, and, when a tactile→visual conjunction error is made, the response will be either CT or TC (one texture correct and one tactile→conjunction error).

Table 8 shows the response percentages given by the participants in Experiment 1. However, in each response category, only texture errors were considered (shape errors were not considered for the reasons given above). Therefore, when a participant made a shape error on one visual stimulus without texture errors, that response was classified as a correct response. In a similar way, a tactile→visual conjunction plus a shape error was classified as a

Table 7  
List of Parameters and Outcome Labels Used in the Model for Experiment 1

Label	Definition
Parameters	
$\beta$ VT	Probability of correctly perceiving or identifying the visual textures
$\alpha$ VT	Probability of binding the visual textures to the right location
$\alpha$ TT	Probability of binding the tactile texture to the right location
Outcomes	
C	Correct
T	Tactile→visual conjunction error
F	Texture feature error
V	Visual conjunction error

Note. In the model, each outcome has been represented with two letters. Each letter represents the response category given for each visual texture. For example, CT means one correct response and one tactile→visual conjunction error.

tactile→visual conjunction error, and the same held for texture feature errors and visual conjunction errors. With this new classification, again the frequency of conjunction errors (9.69%) was significantly higher than the frequency of texture feature errors (5.34%),  $t(15) = 4.185, p < .01$ .

One main assumption we make is that some conjunction errors are real ICs. In the model, the parameter representing tactile texture binding is  $\alpha$ TT. If, in our experiments, cross-modal ICs are caused by incorrect binding of the tactile texture to a visual stimulus location,  $\alpha$ TT should vary according to the frequency of cross-modal ICs: The more frequent any ICs, the smaller the  $\alpha$ TT parameter should be ( $\alpha$ TT = 1 indicates perfect tactile binding).

The data produced by the model are shown in Table 9, with simulations carried out for individual participants. The data are listed according to the frequency of ICs for each participant, calculated simply by subtracting feature errors from conjunction errors made by the participants in Experiment 1 (ICs, last column in Table 9): Smaller differences denote low IC frequencies. The linear relationship between ICs and  $\alpha$ TT (illustrated in Figure 5), measured with the Pearson correlation test, was significant ( $r = -.61, p = .01$ ).

Experiment 6. A similar procedure was also applied to the data from Experiment 6, in which we examined ICs comprising visual textures misreported as being felt. In Experiment 6, two visual stimuli and two tactile stimuli were presented, and the task was to report the two visual shapes—whether the orientation of the two tactile stimuli was the same or different—and the two tactile textures. The presence of two tactile stimuli required some minor adjustment of the model. As in the model for Experiment 1, the model for Experiment 6 was based on the assumptions of independent perception and binding of shape and texture, independent perception of the shapes of different (visual) stimuli, and independent perception of the texture of different (visual) stimuli. As in Experiment 1, in Experiment 6, the participants were exposed to the tactile stimuli for a relatively long duration. Therefore, it is reasonable to assume that tactile perception was very accurate. For this reason, in the model, we assumed perfect tactile perception. As

in the model for Experiment 1, when the binding of a feature failed, that feature was randomly assigned to one of the available locations. Also, features that were not perceived did not take part in the binding process. Calculations for guessing were also based on the assumption that participants guessed (when one or more features were not perceived) in such a way to maximize the probability of being correct, that is, considering that (a) the two visual textures were never the same, (b) the two tactile textures were never the same, (c) one visual texture was the same as one tactile texture, and (d) the visual and tactile stimuli with the same texture were in the same hemisphere in half of trials.

The model included layers corresponding to the following events: perception of the first visual shape (Event 1), perception of the second visual shape (Event 2), binding of the first visual shape (Event 3), binding of the second visual shape (Event 4), perception of the first tactile texture (Event 5), perception of the second tactile texture (Event 6), binding of the first tactile texture (Event 7), and binding of the second tactile texture (Event 8).

The model included three parameters, illustrated in Table 10, representing the probability of correct–incorrect perception and binding of the two visual textures and the two tactile textures. The procedure for parameter determination was the same as the one followed in the model for Experiment 1.

We assumed that ICs from visual to tactile stimuli are caused by incorrect binding of the visual texture, and, for that reason, we expected the parameter  $\alpha$ VT to vary in relation to the number of ICs: The higher the value of  $\alpha$ VT ( $\alpha$ VT = 1 indicates perfect visual binding), the lower the probability of IC errors. The data produced by the model are given in Table 11 (simulations have been carried out for individual participants). The data are ordered according to the frequency of ICs, which is represented by the difference between conjunction and feature errors made by the participants in Experiment 6 (ICs, last column in Table 11). The linear relationship between  $\alpha$ VT and ICs was significant ( $r = -.81, p < .01$ ; Figure 6).

In all the simulations, the probability of cross-modal ICs was strictly correlated to the variation in the binding parameters, even

Table 8  
Percentages of Correct Responses and Errors Given in Experiment 1, in Which Only Errors of Texture Were Considered

Responses	Different texture	Same texture
CC	82.60	87.26
CT/TC	9.69	
CF/FC	5.34	10.49
VV	0.71	0.46
TF/FT	0.33	
VT/TV	0.27	
VF/FV	0.18	0.17
Other errors	0.88	1.62

Note. Errors of shape were not considered. These data were used for the parameter optimization of the model for Experiment 1. CC = both stimuli correct; CT/TC = one texture correct and one tactile→visual conjunction error; CF/FC = one texture correct and one texture feature error; VV = visual conjunction error; TF/FT = one tactile→visual conjunction error and one texture feature error; VT/TV = one visual conjunction error and one tactile→visual conjunction error; VF/FV = one visual conjunction error and one texture feature error.

Table 9  
Parameters and Outcomes Produced by the Model for Each Participant in Experiment 1

Participant	GOF index	Parameters			Responses (%)							
		$\beta$ VT	$\alpha$ VT	$\alpha$ TT	CC	CT/TC	CF/FC	VV	TF/FT	VT/TV	VF/FV	ICs
1	0.0166	0.84	1.00	0.68	79.87	8.06	10.57	0.21	0.44	0.47	0.37	-3.13
9	0.2460	0.91	0.79	0.80	84.66	6.41	5.43	1.98	0.21	0.65	0.66	0.00
7	0.0160	0.95	0.94	0.62	89.51	5.54	4.14	0.30	0.12	0.22	0.18	1.28
4	0.1036	0.97	0.88	0.78	92.40	3.62	2.88	0.67	0.05	0.19	0.19	1.47
12	0.0041	0.89	1.00	0.72	86.32	7.24	5.91	0.04	0.20	0.20	0.08	1.49
6	0.1741	0.87	0.91	0.54	78.32	11.23	7.91	0.66	0.53	0.77	0.57	2.60
3	0.0140	0.91	0.92	0.52	86.90	7.61	4.40	0.36	0.18	0.33	0.22	2.94
14	0.0014	0.92	0.99	0.15	87.02	8.78	3.65	0.07	0.18	0.22	0.08	4.23
16	0.0658	0.82	0.83	0.55	70.36	13.93	10.58	1.41	1.02	1.51	1.20	4.23
2	0.0001	1.00	0.96	0.00	93.89	4.81	1.19	0.01	0.04	0.05	0.01	4.41
10	0.0061	0.96	0.73	0.72	83.26	7.62	4.24	3.07	0.21	0.93	0.67	4.48
5	0.1440	0.88	0.80	0.52	77.64	12.49	6.17	1.40	0.52	1.11	0.67	6.49
11	0.0017	0.94	0.96	0.72	89.74	8.29	1.61	0.06	0.10	0.17	0.03	7.04
15	0.0218	0.87	0.86	0.43	78.97	12.29	6.27	0.70	0.49	0.81	0.47	7.04
8	0.0134	0.95	0.85	0.19	80.21	15.30	2.35	0.68	0.29	1.00	0.18	11.54
13	0.0217	0.94	0.85	0.11	79.91	15.20	3.11	0.41	0.37	0.81	0.19	13.43

Note. The first column lists each participant's number; participants were ordered according to frequency of ICs (the difference between conjunction and feature errors; see the ICs column). The second column lists goodness-of-fit (GOF) index values. The third–fifth columns list values for the parameters of the model ( $\beta$ VT = probability of correctly perceiving or identifying the visual textures;  $\alpha$ VT = probability of binding the visual textures to the right location;  $\alpha$ TT = probability of binding the tactile texture to the right location). The sixth–twelfth columns list the percentages of responses for each response category (CC = both stimuli correct; CT/TC = one texture correct and one tactile  $\rightarrow$  visual conjunction error; CF/FC = one texture correct and one texture feature error; VV = visual conjunction error; TF/FT = one tactile  $\rightarrow$  visual conjunction error and one texture feature error; VT/TV = one visual conjunction error and one tactile  $\rightarrow$  visual conjunction error; VF/FV = one visual conjunction error and one texture feature error). ICs = illusory conjunctions.

when the probability of guessing was maximized. These results further support the idea that cross-modal ICs were caused by incorrect binding of the textures to their stimulus, and that, under condition of low attention, information about the stimulus modality can be lost in such a way that miscombinations of features of different modalities can occur.

General Discussion

We have presented evidence across six experiments that indicates that cross-modal ICs occur under conditions of divided attention, in which felt textures are reported as seen textures and

seen textures are reported as felt textures. Experiment 1 demonstrated the basic occurrence of cross-modal ICs from tactile to visual stimuli, at a rate greater than expected from tactile texture feature errors made to the visual stimuli. Experiment 2 provided evidence for a perceptual contribution to these errors, because under one condition of the study, cross-modal ICs were increased when the tactile and visual stimuli fell in the same hemispace. This conclusion is also supported by the data from Experiments 3, 4, and 5. In Experiment 3, cross-modal ICs were found under forced-choice conditions chosen to minimize effects of memory on report. In Experiment 4, participants were also asked to report the tactile

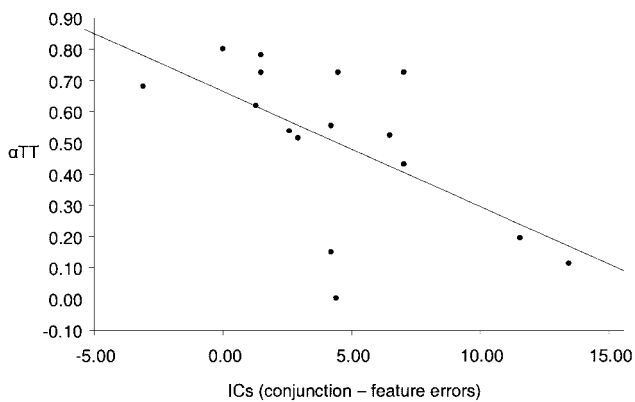

Figure 5. Results for parameter  $\alpha$ TT ( $r = -.609, p = .01$ ) from the model simulation of Experiment 1, in relation to the difference between conjunction and feature errors for each participant.  $\alpha$ TT = probability of binding the tactile texture to the right location; ICs = illusory conjunctions.

Table 10  
List of Parameters and Outcome Labels Used in the Model for Experiment 6

Label		Definition
Parameters		
$\beta$ VT		Probability of correctly perceiving or identifying the visual textures
$\alpha$ VT		Probability of binding the visual textures to the right location
$\alpha$ TT		Probability of binding the tactile texture to the right location
Outcomes		
C		Correct
V		Visual $\rightarrow$ tactile conjunction error
F		Texture feature error

Note. In the model, each outcome has been represented with two letters. Each letter represents the response category given for each tactile texture. For example, CV means one correct and one visual  $\rightarrow$  tactile conjunction error.

Table 11  
Parameters and Outcomes Produced by the Model for Each Participant in Experiment 6

Participant	GOF index	Parameters			Responses (%)				
		$\beta$ VT	$\alpha$ VT	$\alpha$ TT	CC	CV/VC	CF/FC	Other	ICs
1	0.000386	0.84	1.00	1.00	88.80	5.52	5.33	0.30	-2.78
9	0.000097	0.79	1.00	1.00	88.50	5.62	5.62	0.27	-1.39
14	0.000025	0.91	1.00	1.00	94.59	2.70	2.70	0.00	-0.69
10	0.000003	0.89	0.91	1.00	93.80	3.23	2.82	0.07	0.69
16	0.000003	0.94	0.89	1.00	96.83	1.79	1.22	0.10	0.69
2	0.000012	0.87	0.85	1.00	91.83	4.54	3.03	0.36	1.39
4	0.000009	1.00	0.80	1.00	97.21	1.78	0.51	0.44	1.39
12	0.000047	0.94	1.00	0.85	96.75	1.81	0.97	0.39	1.39
6	0.000013	0.50	0.89	1.00	68.98	15.77	14.21	0.64	1.39
7	0.000022	0.94	0.78	1.00	92.43	4.42	2.31	0.60	2.08
5	0.000146	0.95	1.00	0.74	92.69	4.22	1.63	1.21	2.78
13	0.000039	0.95	0.74	1.00	93.61	3.98	1.52	0.69	2.78
15	0.000039	0.95	0.74	1.00	93.23	4.21	1.74	0.61	2.78
3	0.000061	0.95	0.70	1.00	91.08	5.87	1.72	1.03	3.47
11	0.000125	0.86	0.66	1.00	88.50	7.02	2.96	1.07	4.86
8	0.000188	0.62	0.66	1.00	71.28	15.72	10.99	1.00	5.56
Average	0.000016	0.86	0.83	1.00	92.45	4.17	2.99	0.20	1.65

*Note.* The first column lists each participant's number; participants were ordered according to frequency of ICs (the difference between conjunction and feature errors; see the ICs column). The second column lists goodness-of-fit (GOF) index values. The third–fifth columns list the values for the parameters of the model ( $\beta$ VT = probability of correctly perceiving or identifying the visual textures;  $\alpha$ VT = probability of binding the visual textures to the right location;  $\alpha$ TT = probability of binding the tactile texture to the right location). The sixth–ninth columns list the percentages of responses for each response category (CC = both stimuli correct; CV/VC = one correct and one visual→tactile conjunction error; CF/FC = one correct and one texture feature error; Other = other errors). ICs = illusory conjunctions.

texture, to force them to pay more attention to that stimulus. In those circumstances, we did not find cross-modal ICs, despite the higher memory load. Consequently, there is converging evidence that these cross-modal ICs were perceptual in nature. Under conditions in which there is suboptimal attention to the stimuli, ICs can occur, in which stimulus features within one modality are combined incorrectly (e.g., Treisman & Schmidt, 1982). In Experiment 5, we found evidence for cross-modal ICs using relatively long exposures of stimuli in a patient with damage to the parietal lobe (M.H.). ICs occurred when there was concurrent presentation

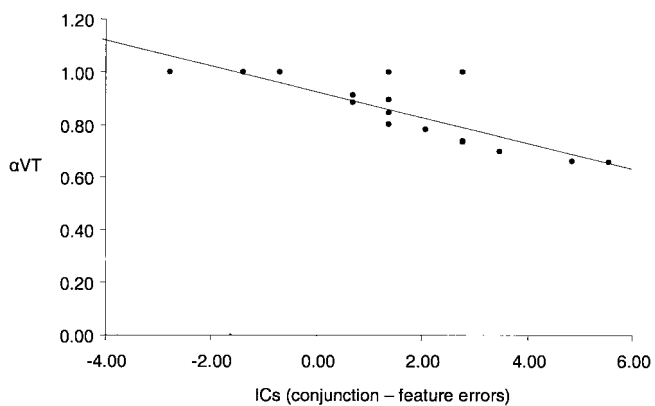

Figure 6. Results for parameter  $\alpha$ VT ( $r = -.81, p < .01$ ) from the model simulation of Experiment 6, in relation to the difference between conjunction and feature errors for each participant.  $\alpha$ VT = probability of binding the visual textures to the right location; ICs = illusory conjunctions.

of the felt and seen textures (in the perception condition), but not when their presentations were staggered (in the memory condition). In Experiment 6, we found that cross-modal ICs of a visual texture to a tactile stimulus are also possible and that these occurred with a similar frequency to cross-modal ICs to the visual stimuli (found in Experiment 2). The ICs in Experiments 1 and 6 cannot be considered experimental artifacts due to clever guessing, as indicated by our multinomial probabilistic model.

To the best of our knowledge, this is the first time that reliable ICs have been demonstrated across, as well as within, modalities. As is the case with within-modality ICs, we suggest that cross-modal ICs arise under conditions of inattention to the stimuli. In Experiments 1–3 and 5, participants were asked to make a judgment about the orientation of the tactile stimulus, but the texture of the stimulus was not relevant to the tasks. Nevertheless, although the tactile texture was not attended to as part of the response set, it influenced performance. There was also some suggestion that the effect of the tactile texture was strongest under conditions of inattention. This was confirmed in Experiment 4, in which the tactile texture also had to be reported, with the effect that cross-modal ICs to the visual stimuli did not occur any more. Also, cross-modal ICs were maximized for normal participants when they felt (and attended to) a constant texture with their preferred (right) hand, when migrations increased from the texture felt with the left hand to the visual stimulus presented in the left visual field (Experiment 2). We suggest that textures felt by the left hand were unattended in this condition. The errors found in patient M.H. are also consistent with this. Damage to the parietal lobe is associated with impairments of attention, particularly to the contralesional

side (and note M.H.'s pattern of right-side extinction, which is consistent with an attention deficit). M.H. showed high numbers of cross-modal ICs even with prolonged presentation of the visual stimuli, and these tended to be greater when visual stimuli fell on his contralesional side (in the right visual field). We propose that these errors arose when insufficient attention was allocated to the felt texture, enabling it to compete for selection with the seen textures.

### *Cross-Modal ICs in Perception or Memory?*

In Experiments 3, 4, and 5, we also provided explicit tests of whether the cross-modal ICs were due to memory failures rather than to impaired perceptual binding of stimulus to modality. On no occasion did we find evidence for the errors arising in memory. Thus, in Experiment 3, cross-modal ICs were found under forced-choice conditions, and they were particularly represented in false positive errors on absent trials (they were less likely to be reflected in full report errors on present trials). In Experiment 5, the parietal patient M.H. did not make cross-modal ICs errors when the visual stimuli were presented before the tactile stimuli, even though the stimuli then had to be retained for longer. In Experiment 4, we had participants report the tactile texture in addition to the visual shapes and texture. Again, this increased the report load of the task; however, in this case, attention was more likely to be paid to the tactile texture (relative to when it was irrelevant to report). Despite the greater stress on memory, no cross-modal ICs were apparent. Our data suggest that the cross-modal errors were failures of perceptual binding rather than memory.

The empirical conclusions from Experiments 3–5 are supported by the formal models developed to account for performance. The best fitting models had a parameter specifying the likelihood that modality-specific binding occurred, and variations in this parameter across participants predicted the magnitude of cross-modal ICs (relative to feature errors). This formal account again holds that cross-modal ICs are perceptual in nature.

### *Cross-Modal Integration*

The present evidence for cross-modal ICs suggests that there is multimodal integration of sensory information in perception so that misattributions of modalities arise under conditions of inattention. The argument for cross-modal integration of sensory information is supported by the recent work, noted in the introduction, on cross-modal influences on attentional orienting (see Driver & Spence, 1998a, 1998b). For instance, evidence of visual–tactile links in spatial endogenous attention has been found, suggesting that spatial distribution of endogenous attention in one modality tends to spread in other modalities (Spence et al., 2000). There is also older literature on perceptual dominance (e.g., see Klein & Posner, 1974; Posner, Nissen, & Klein, 1976), which shows that, when competing information is presented across two sensory modalities, there can be competition with information in one modality tending to dominate. For example, when either vision and touch or vision and audition are set in opposition, vision typically dominates (e.g., see Bertelson, 1998; Gibson, 1933; MacDonald & McGurk, 1978). In the present case, we did not pit touch and vision against one another, but rather assessed whether there are influences carried over implicitly from one modality to another. We

found effects from touch on vision as well as effects from vision to touch. This is consistent with previous findings showing that vision does not necessarily dominate over touch. For instance, in a study investigating visual dominance over touch, Klein (1977) found that the effects of an unattended visual distractor on the detection of a tactile target are the same as the effects of a tactile distractor on the detection of a visual target. More recent studies have shown that there are cross-modal links in spatial attention, so that, for example, a tactile cue can influence the orientation of visual attention and vice versa (Driver & Spence, 1998b). It appears that either visual or tactile information, coded implicitly, influences each other in perceptual judgments.

One potential locus for cross-modal integration in the brain is the parietal lobe, which is also known to play an important role in spatial attention (e.g., Andersen, Snyder, Bradley, & Xing, 1997; Banati, Goerres, Tjoa, Aggleton, & Grasby, 2000; Macaluso, Frith, & Driver, 2000a, 2000b). For example, in a tactile–visual matching task in which participants had to make a cross-modal match between a tactile stimulus and some visual stimuli, Banati et al. (2000) found that the inferior parietal lobes were among the areas where an increased activity was detected. The data from Experiment 5 here also indicate that cross-modal integration can be disrupted after parietal damage, so that even with relatively long visual presentation conditions, an observer may tend to report a felt texture as being seen. It is possible that the normal cross-modal integration process involves tagging information to coregister it with information from other modalities. Parietal damage may disrupt the ability to read such tags, so that inputs are misattributed to the wrong modality of origin.

### References

- Andersen, R. A., Snyder, L. H., Bradley, D. C., & Xing, J. (1997). Multimodal representation of space in the posterior parietal cortex and its use in planning movement. *Annual Review in Neuroscience*, *20*, 303–330.
- Ashby, F. G., Prinzmetal, W., Ivry, R., & Maddox, W. T. (1996). A formal theory of feature binding in object perception. *Psychological Review*, *103*, 165–192.
- Banati, R. B., Goerres, G. W., Tjoa, C., Aggleton, J. P., & Grasby, P. (2000). The functional anatomy of visual–tactile integration in man: A study using positron emission tomography. *Neuropsychologia*, *38*, 115–124.
- Bertelson, P. (1998). Starting from the ventriloquist: The perception of multimodal events. In M. Sabourin, F. I. M. Craik, & M. Rober (Eds.), *Advances in psychological sciences: Vol. 1. Biological and cognitive aspects*. Hove, England: Psychology Press.
- Buchtel, H. A., & Butter, C. M. (1988). Spatial attention shifts: Implication for the role of polysensory mechanisms. *Neuropsychologia*, *26*, 499–509.
- Butter, C. M., Buchtel, H. A., & Santucci, R. (1989). Spatial attentional shifts: Further evidence for the role of polysensory mechanisms using visual and tactile stimuli. *Neuropsychologia*, *27*, 1231–1240.
- Cohen, A., & Ivry, R. (1989). Illusory conjunctions inside and outside the focus of attention. *Journal of Experimental Psychology: Human Perception and Performance*, *15*, 650–663.
- Cohen, A., & Rafal, R. D. (1991). Attention and feature integration: Illusory conjunctions in a patient with a parietal lobe lesion. *Psychological Science*, *2*, 106–110.
- Cytowic, R. E. (1989). *Synesthesia: A union of the senses*. New York: Springer-Verlag.
- Donk, M. (1999). Illusory conjunctions are illusions: The effect of target–

- nontarget similarity on conjunction and feature errors. *Journal of Experimental Psychology: Human Perception and Performance*, 25, 1207–1233.
- Driver, J., & Spence, C. (1998a). Attention and the cross-modal construction of space. *Trends in Cognitive Science*, 2, 254–262.
- Driver, J., & Spence, C. (1998b). Cross-modal links in spatial attention. *Philosophical Transactions of the Royal Society of London, Series B*, 353, 1319–1331.
- Duncan, J. (1980). The locus of interference in the perception of simultaneous stimuli. *Psychological Review*, 87, 272–300.
- Farah, M. J., Wong, A. B., Monheit, M. A., & Morrow, L. A. (1989). Parietal lobe mechanisms of spatial attention: Modality specific or supramodal? *Neuropsychologia*, 27, 461–470.
- Friedman-Hill, S. R., Robertson, L. C., & Treisman, A. (1995, August 11). Parietal contribution to visual feature binding: Evidence from a patient with bilateral lesion. *Science*, 269, 853–855.
- Gibson, J. J. (1933). Adaptation, after-effect and contrast in the perception of curved lines. *Journal of Experimental Psychology*, 16, 1–31.
- Hall, M. D., Pastore, R. E., Acker, B. E., & Huang, W. (2000). Evidence for auditory feature integration with spatially distributed items. *Perception & Psychophysics*, 62, 1243–1257.
- Heller, M. A. (1982). Visual and tactual texture perception: Intersensory cooperation. *Perception & Psychophysics*, 31, 339–344.
- Humphreys, G. W., Cinel, C., Wolfe, J., Olson, A., & Klempen, N. (2000). Fractionating the binding process: Neuropsychological evidence distinguishing binding of form from binding of surface features. *Vision Research*, 40, 1569–1596.
- Jones, B., & O'Neil, S. (1985). Combining vision and touch in texture perception. *Perception & Psychophysics*, 37, 66–72.
- Khurana, B. (1998). Visual structure and the integration of form and color information. *Journal of Experimental Psychology: Human Perception and Performance*, 24, 1766–1785.
- Klatzky, R. L., Lederman, S. J., & Matula, D. E. (1993). Haptic exploration in the presence of vision. *Journal of Experimental Psychology: Human Perception and Performance*, 19, 726–743.
- Klein, R. M. (1977). Attention and visual dominance: A chronometric analysis. *Journal of Experimental Psychology: Human Perception and Performance*, 3, 365–378.
- Klein, R. M., & Posner, M. I. (1974). Attention to visual and kinesthetic component of skills. *Brain Research*, 71, 401–411.
- Lederman, S. J., & Abbott, S. G. (1981). Texture perception: Studies of intersensory organization using a discrepancy paradigm, and visual versus tactile psychophysics. *Journal of Experimental Psychology: Human Perception and Performance*, 4, 902–915.
- Lederman, S. J., Thorne, G., & Jones, B. (1986). Perception of texture by vision and touch: Multidimensionality and intersensory integration. *Journal of Experimental Psychology: Human Perception and Performance*, 12, 169–180.
- Macaluso, E., Frith, C., & Driver, J. (2000a, August 18). Modulation of human visual cortex by crossmodal spatial attention. *Science*, 289, 1206–1208.
- Macaluso, E., Frith, C., & Driver, J. (2000b). Selective spatial attention in vision and touch: Unimodal and multimodal mechanisms revealed by PET. *Journal of Neurophysiology*, 83, 3062–3075.
- MacDonald, J., & McGurk, H. (1978). Visual influences on speech perception. *Perception & Psychophysics*, 24, 253–257.
- Mattingley, J. B., Driver, J., Beschin, N., & Robertson, I. J. (1997). Attentional competition between modalities: Extinction between touch and vision after right hemisphere damage. *Neuropsychologia*, 35, 867–880.
- McClelland, J. L., & Johnston, J. C. (1977). The role of familiar units in perception of words and nonwords. *Perception & Psychophysics*, 22, 249–261.
- McGurk, H., & MacDonald, J. (1976, December 23–30). Hearing lips and seeing voices: A new illusion. *Nature*, 264, 746–748.
- Posner, M. I., Nissen, M. J., & Klein, R. M. (1976). Visual dominance: An information-processing account of its origins and significance. *Psychological Review*, 83, 157–171.
- Prinzmetal, W. (1981). Principles of feature integration in visual attention. *Perception & Psychophysics*, 30, 330–340.
- Prinzmetal, W., Henderson, D., & Ivry, R. (1995). Loosening the constraints on illusory conjunctions: Assessing the roles of exposure duration and attention. *Journal of Experimental Psychology: Human Perception and Performance*, 21, 1362–1375.
- Prinzmetal, W., Ivry, R., Beck, D., & Shimizu, N. (2002). A measurement theory of illusory conjunctions. *Journal of Experimental Psychology: Human Perception and Performance*, 28, 251–269.
- Reicher, G. M. (1969). Perceptual recognition as a function of meaningfulness of stimulus material. *Journal of Experimental Psychology*, 81, 275–289.
- Riddoch, M. J. (2002). [Report of investigations with the patient M.H.]. Unpublished report (updated regularly). Edgbaston, United Kingdom: The University of Birmingham.
- Rock, I., & Victor, J. (1964, February 7). Vision and touch: An experimentally created conflict between the two senses. *Science*, 143, 594–596.
- Spence, C., & Driver, J. (1997). Audiovisual links in exogenous covert spatial orienting. *Perception & Psychophysics*, 59, 1–22.
- Spence, C., & Driver, J. (1998). Cross-modal links in exogenous covert spatial orienting between touch, audition and vision. *Perception & Psychophysics*, 60, 544–557.
- Spence, C., Nicholls, M. E. R., Gillespie, N., & Driver, J. (1998). Cross-modal links in exogenous covert spatial orienting between touch, audition, and vision. *Perception & Psychophysics*, 60, 544–557.
- Spence, C., Pavani, F., & Driver, J. (2000). Crossmodal links between vision and touch in covert endogenous spatial attention. *Journal of Experimental Psychology: Human Perception and Performance*, 26, 1298–1319.
- Stein, B. E., & Wallace, M. T. (1996). Comparison of cross-modality integration in midbrain and cortex. *Progress in Brain Research*, 112, 289–299.
- Stein, B. E., & Wallace, M. T. (1999). The integration of multiple sensory signals in cortical neurons. *Brain and Cognition*, 40, 22–23.
- Treisman, A. (1988). Features and objects—The 14th Bartlett memorial lecture. *Quarterly Journal of Experimental Psychology: Human Experimental Psychology*, 40(A), 201–237.
- Treisman, A. (1998). Feature binding, attention and object perception. *Philosophical Transactions of the Royal Society of London, Series B*, 353, 1295–1306.
- Treisman, A., & Gelade, G. (1980). A feature integration theory of attention. *Cognitive Psychology*, 12, 97–136.
- Treisman, A., & Schmidt, H. (1982). Illusory conjunctions in the perception of objects. *Cognitive Psychology*, 14, 107–141.
- Virzi, R. A., & Egeth, H. E. (1984). Is meaning implicated in illusory conjunctions? *Journal of Experimental Psychology: Human Perception and Performance*, 10, 573–580.
- Warrington, E. K., & James, M. (1991). *VOSP: The visual object and space perception battery*. Bury St. Edmunds, Suffolk, England: Thames Valley Test Company.
- Wheeler, D. D. (1970). Processes in word recognition. *Cognitive Psychology*, 1, 59–85.
- Wilson, B. A., & Cockburn, J. (1987). *Behavioural inattention test*. Bury St. Edmunds, Suffolk, England: Thames Valley Test Company.

Appendix

Tree Diagrams of the Model for Experiment 1

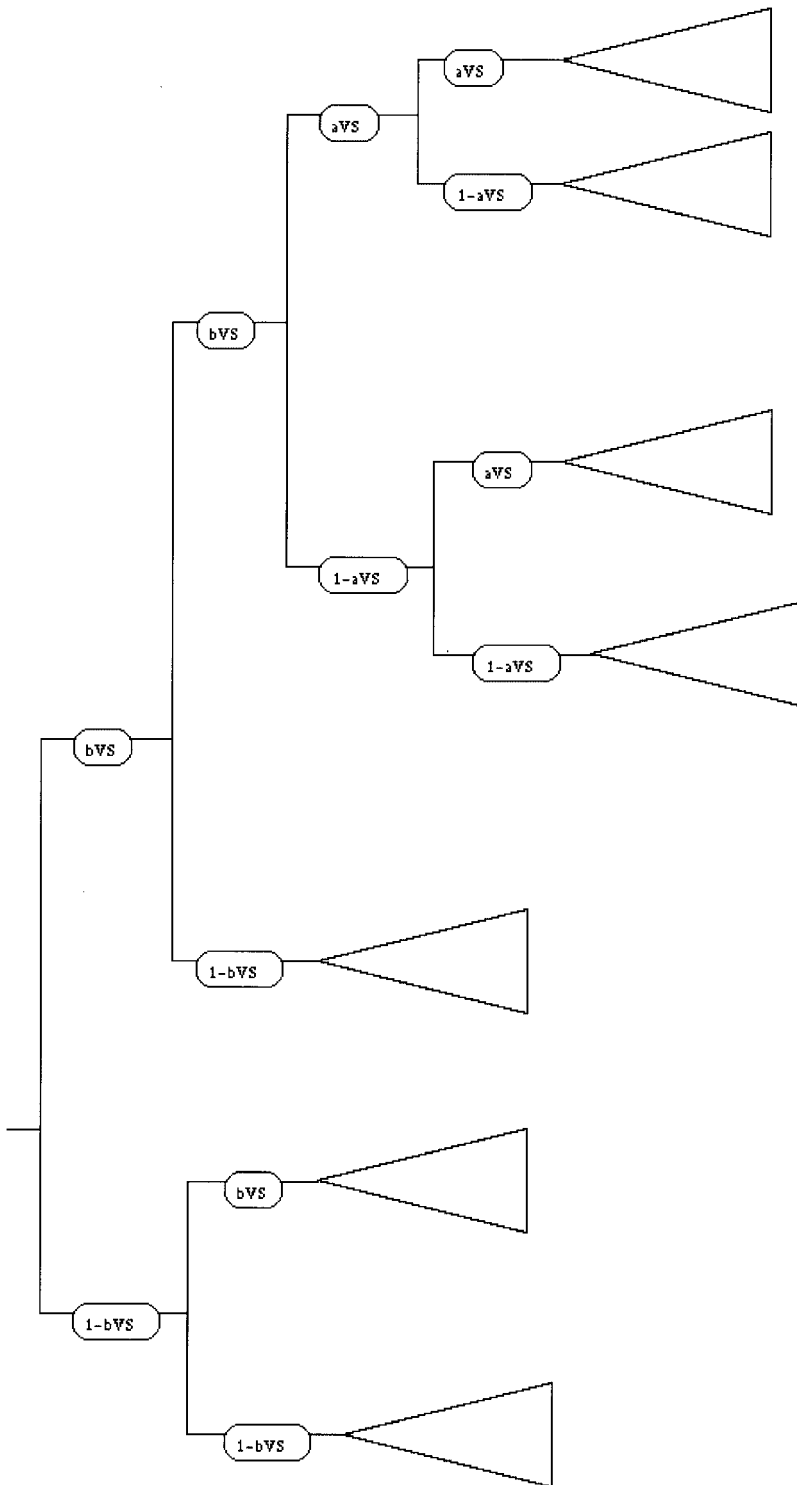

Figure A1.  $bVS = \beta VS$  = probability that one of the visual shapes is correctly perceived or identified;  $aVS = \alpha VS$  = probability of binding one of the visual shapes to the right location.

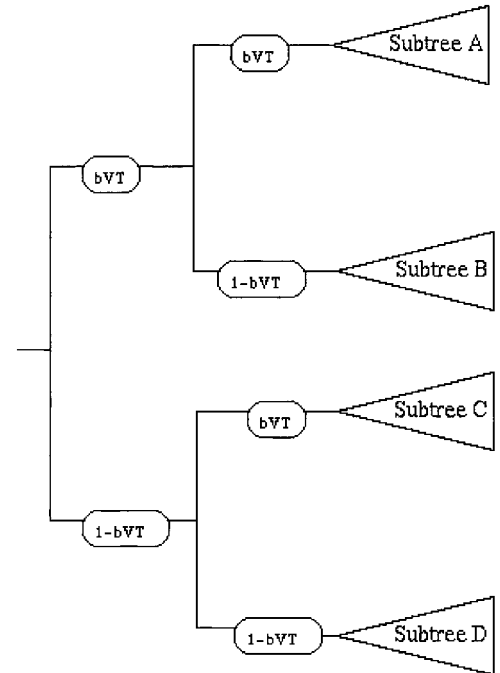

Figure A2.  $bVT = \beta VT$  = probability that one of the visual textures is correctly perceived or identified.

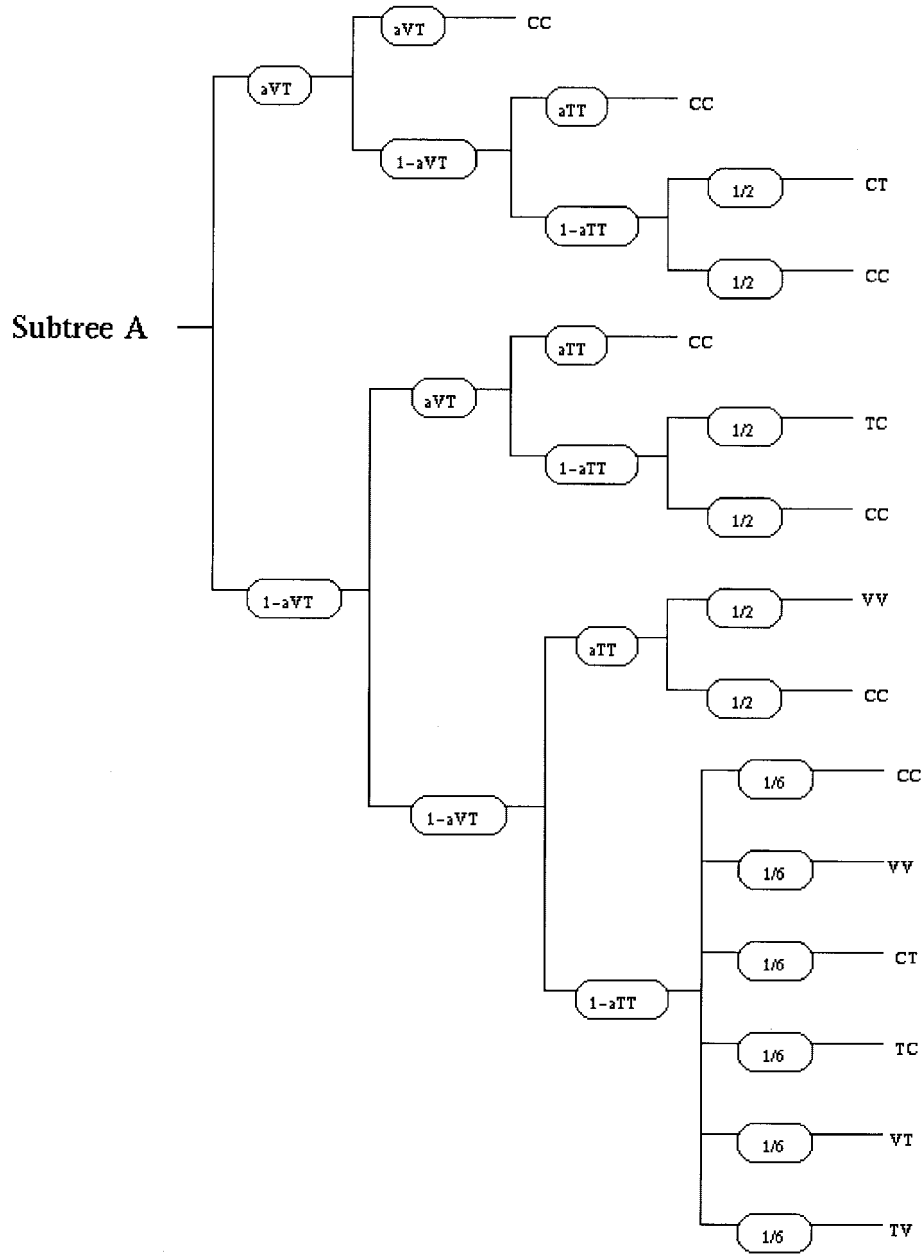

Figure A3.  $aVT = \alpha VT$  = probability of binding one of the visual textures to the right location;  $CC$  = both stimuli reported correctly;  $aTT = \alpha TT$  = probability of binding the tactile texture to the right location;  $CT$  and  $TC$  = one stimulus correct and one with a tactile→visual conjunction error;  $VV$  = visual conjunction error;  $VT$  and  $TV$  = one stimulus with a visual conjunction error and one with a tactile→visual conjunction error.

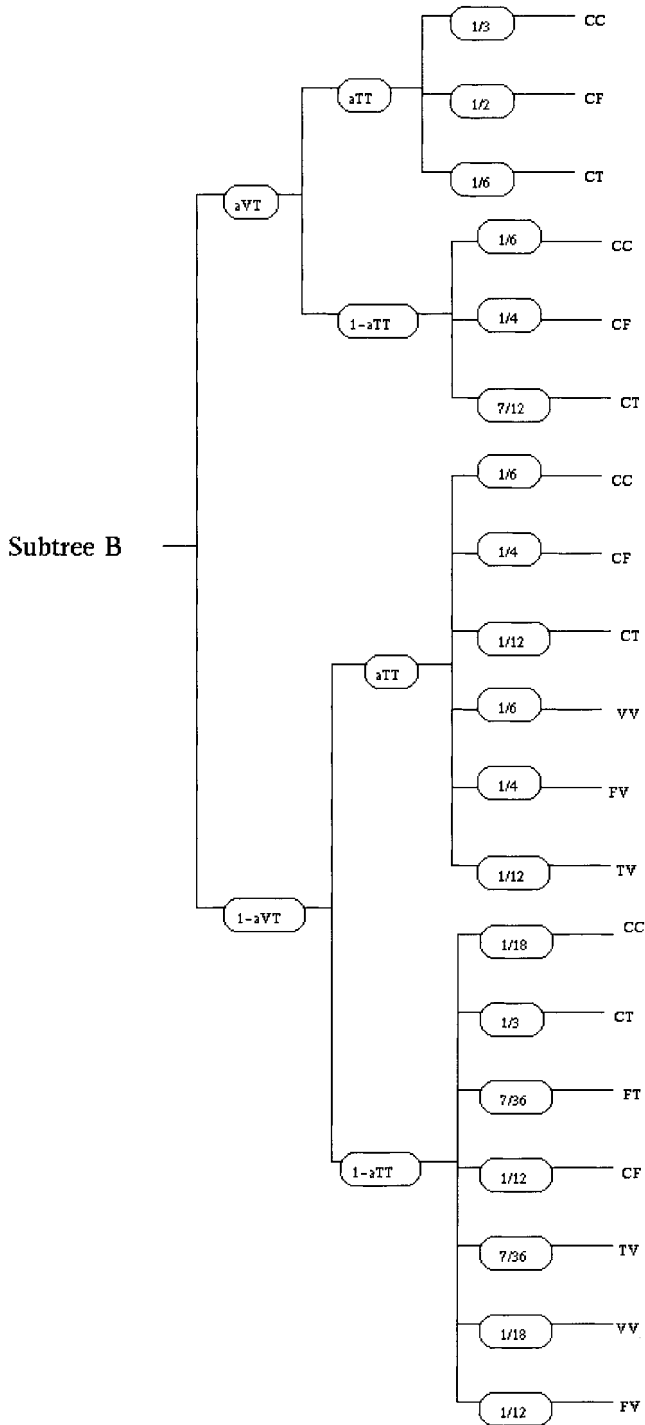

Figure A4.  $aVT = \alpha VT$  = probability of binding one of the visual textures to the right location;  $aTT = \alpha TT$  = probability of binding the tactile texture to the right location; CC = both stimuli reported correctly; CF = one stimulus correct and one with a texture feature error; CT = one stimulus correct and one with a tactile→visual conjunction error; VV = visual conjunction error; FV = one stimulus with a texture feature error and one with a visual conjunction error; TV = one stimulus with a visual conjunction error and one with a tactile→visual conjunction error; FT = one stimulus with a tactile→visual conjunction error and one with a texture feature error.

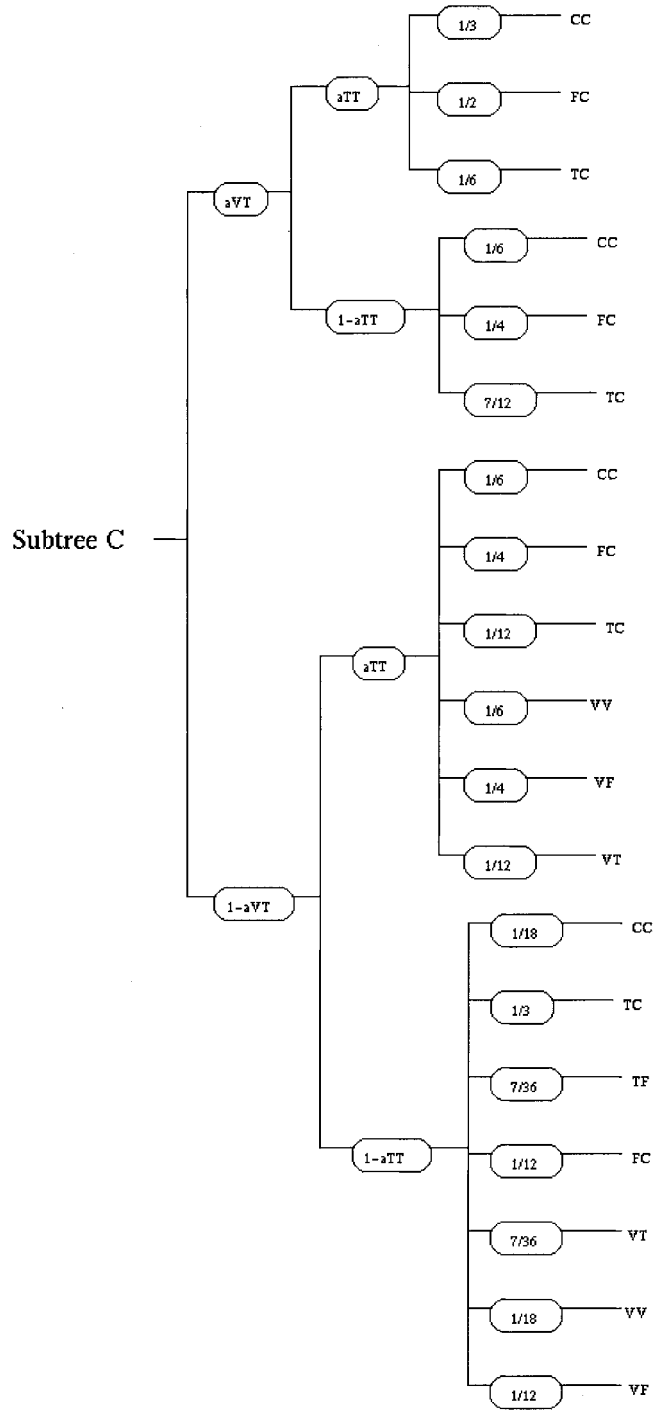

Figure A5.  $aVT = \alpha VT$  = probability of binding one of the visual textures to the right location;  $aTT = \alpha TT$  = probability of binding the tactile texture to the right location; CC = both stimuli reported correctly; FC = one stimulus correct and one with a texture feature error; TC = one stimulus correct and one with a tactile→visual conjunction error; VV = visual conjunction error; VF = one stimulus with a texture feature error and one with a visual conjunction error; VT = one stimulus with a visual conjunction error and one with a tactile→visual conjunction error; TF = one stimulus with a tactile→visual conjunction error and one with a texture feature error.

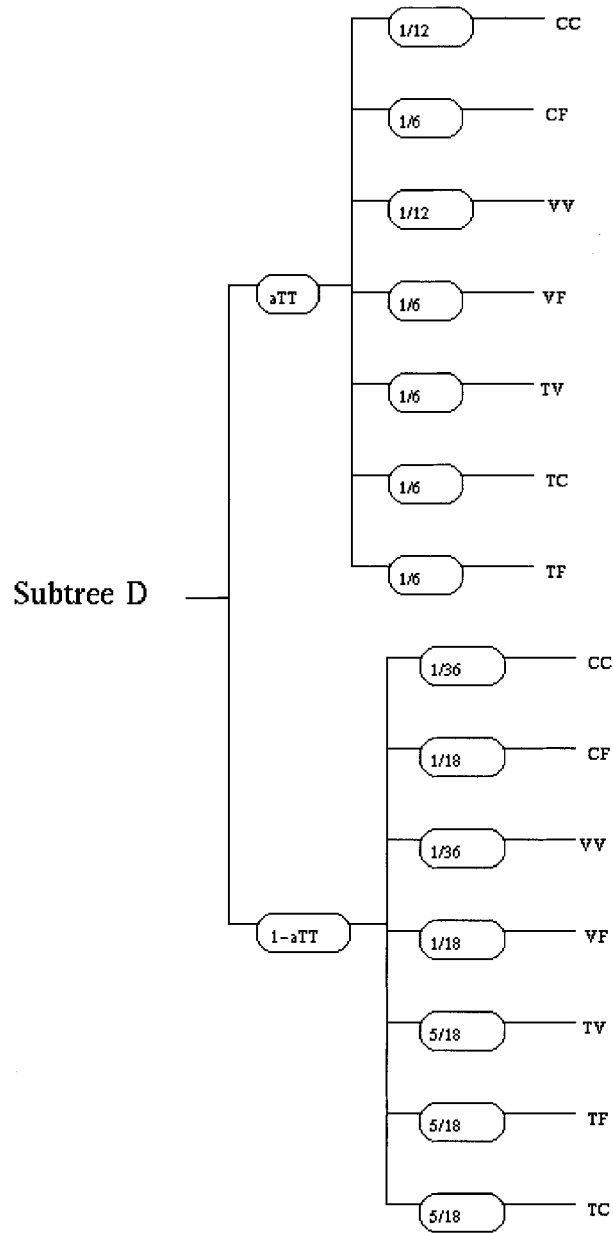

Figure A6.  $aTT = \alpha TT$  = probability of binding the tactile texture to the right location; CC = both stimuli reported correctly; CF = one stimulus correct and one with a texture feature error; VV = visual conjunction error; VF = one stimulus with a texture feature error and one with a visual conjunction error; TV = one stimulus with a visual conjunction error and one with a tactile→visual conjunction error; TC = one stimulus correct and one with a tactile→visual conjunction error; TF = one stimulus with a tactile→visual conjunction error and one with a texture feature error.

Received December 13, 2000  
 Revision received January 3, 2002  
 Accepted March 22, 2002 ■